

9729 Optical Wavelength Division Multiplexer



Maintenance Information

9729 Optical Wavelength Division Multiplexer



Maintenance Information

Note

Before using this information and the product it supports, be sure to read the general information under "Notices" on page vii.

Third Edition (September 1997)

This edition applies to the IBM 9729 Optical Wavelength Division Multiplexer Version 1, Release 3.

Order publications through your IBM representative or the IBM branch office serving your locality. Publications are not stocked at the address given below.

A form for readers's comments appears at the back of this publications. If the form has been removed, address your comments to:

Department CGF
Design & Information Development
IBM Corporation
PO Box 12195
RESEARCH TRIANGLE PARK NC 27709
USA

When you send information to IBM, you grant IBM a nonexclusive right to use or distribute the information in any way it believes appropriate without incurring any obligation to you.

© **Copyright International Business Machines Corporation 1996, 1997. All rights reserved.**

Note to U.S. Government Users — Documentation related to restricted rights — Use, duplication or disclosure is subject to restrictions set forth in GSA ADP Schedule Contract with IBM Corp.

Contents

Notices	vii
Safety Inspection Procedures	viii
Safety Labels	x
Sicherheitsüberprüfungen	xii
Electronic Emission Notices	xiii
Industry Canada Class A Emission Compliance Statement	xiii
Avis de conformité aux normes d'Industrie Canada	xiii
European Community (CE) Mark of Conformity Statement	xiii
Japanese Voluntary Control Council for Interference (VCCI) Statement	xiv
Korean Communications Statement	xv
Trademarks	xv
About This Manual	xvii
Who Should Read This Manual	xvii
How This Manual Is Organized	xvii
Chapter 1. Introduction	1
Front Panel Reference	2
Physical Description	4
Cable Specifications	4
Chapter 2. Installation and Operation	7
Chapter 3. Troubleshooting Procedures	11
All LEDs on Front Panel OFF	12
PS1 or PS2 Indicator ON on Diagnostic Card	14
Diagnostic Card Green Int LED Not Flashing	16
Amber Grating Temp LED on Diagnostic Card ON	17
Green Ready LEDs OFF on All LRCs at Both Ends, or Primary & Secondary LEDs on Dual Fiber I/O Card Toggling On and Off	19
Green Ready LED Flashing on LRC in Unit A while OFF on Corresponding LRC in Unit B	21
Green Ready LED OFF on LRC in Both Unit A and Unit B	23
Device Attached to a 9729 Channel X Logs an Error	24
IOC Light LED OFF	25
SNMP Monitor Cannot Access the 9729	25
Amber Temp LED on TEC Card ON	26
Amber Open LED on TEC Card ON	26
Amber Short LED on TEC Card ON	27
Amber Fault LED on ISC IOC ON	27
Chapter 4. Removal and Replacement Procedures	29
Required Test Equipment	29
Periodic Maintenance	29
Measuring Received Optical Power and Tuning LRC Wavelength	30
Removing and Replacing a Generic Card	31
Removing and Replacing an LRC	34
Removing and Replacing the Diagnostic Card	35
Removing and Replacing the TEC Card	38
Removing and Replacing an IOC	39

Removing and Replacing the Fiber I/O Card or Dual Fiber I/O Card	40
Removing and Replacing the Grating Assembly	41
Removing and Replacing Optical Adapters	43
Removing and Replacing a Power Distribution Unit (PDU)	45
Removing and Replacing a Power Supply	48
Removing and Replacing the Backplane	51
Removing and Replacing the Fan Tray	51
Removing and Replacing the Fan Filter	53
Removing and Replacing the Fan Cable	54
Removing and Replacing the Dropdown Panel	55
Card Cage/Grating Removal, Disassembly, and Reassembly	56
Removing the Card Cage Assembly	56
Disassembling the Card Cage Assembly	57
Reassembling the Card Cage Assembly	58
Replacing the Grating Fan	60
Replacing Coaxial Cable	61
Testing the Operation of Open-Fiber Detection Circuitry	62
Appendix A. Translated Safety Notices	65
9729 ISC Card Laser Safety Compliance Requirements	65
Safety	65
Danger Notices	66
Caution Notice	75
Appendix B. 9729 Wiring and Power Plug Information	79
Simplified Wiring Diagrams	79
Wiring for 9729 with Redundant Power System	79
Wiring for 9729 without Redundant Power System	79
Power Plug Requirements	80
Index	83

Figures

1.	9729 Front Panel Reference	2
2.	Physical Planning	7
3.	Backplane Connections Viewed from the Front	13
4.	diagnostic card LEDs	16
5.	Diagnostic Card LEDs	17
6.	LRC LED	19
7.	Laser-Receiver Card LED	21
8.	Laser/Receiver Card LED	23
9.	IOC LED	25
10.	Laser Adjustment Setup	30
11.	Generic Card Removal from Bottom Row	32
12.	Generic Card Removal from Top Row	33
13.	LRC Removal and Replacement	34
14.	LRC Jumper Locations	35
15.	Diagnostic Card Removal and Replacement	36
16.	Diagnostic Card Jumpers	37
17.	TEC Card Removal and Replacement	38
18.	IOC Removal and Replacement	39
19.	Fiber I/O Card	40
20.	PDU1 Removal	46
21.	Removing PS1	49
22.	Fan-Tray Locking Bracket and Fan Tray	52
23.	Fan Filter Removal	54
24.	9729 Redundant Power System	79
25.	9729 Non-redundant Power System	79
26.	9729 Power Plug Identification	80
27.	Power Plug Requirements by Country (200–250 volts)	81

Notices

References in this publication to IBM products, programs, or services do not imply that IBM intends to make these available in all countries in which IBM operates. Any reference to an IBM product, program, or service is not intended to state or imply that only IBM's product, program, or service may be used. Any functionally equivalent product, program, or service that does not infringe any of IBM's intellectual property rights may be used instead of the IBM product, program, or service. Evaluation and verification of operation in conjunction with other products, except those expressly designated by IBM, are the user's responsibility.

IBM may have patents or pending patent applications covering subject matter in this document. The furnishing of this document does not give you any license to these patents. You can send license inquiries, in writing, to the IBM Director of Licensing, IBM Corporation, 500 Columbus Avenue, THORNWOOD NY 10594 USA.

Safety Inspection Procedures

The following procedures guide the IBM service representative in determining whether this IBM product conforms to IBM safety and installation criteria. Make these checks each time you question the safety of the product.

Report to the owner or user any deficiencies that make the product unsafe. Then, before performing any repairs, correct these deficiencies by:

- Following the instructions on this page
- Ordering the missing or failing parts using information given in this book.

Use the procedures on this page to check the following parts and functions:

1. External covers
2. Safety labels
3. Grounding
4. Input power voltage

Note: Perform these procedures with the power off. Switch the power off and unplug each unit.

1 EXTERNAL COVERS

Check that:

- The cover is present on each unit.
- The unit has appropriate clearance and access.

2 SAFETY LABELS

Check that:

- All safety labels are placed correctly, as indicated in the figure on page x.
- Each safety label is the correct one, as indicated in the figure on page x.

3 GROUNDING

Check that your power system is correctly grounded. Refer to *Electrical Safety for IBM Customer Engineers*, S229-8124, for procedures.

4 INPUT POWER VOLTAGE

Check that your customer's power receptacle provides ac power with a line frequency of 50 or 60 Hz and a voltage range of 90 to 137 volts or 180 to 265 volts. Refer to *Electrical Safety for IBM Customer Engineers*, S229-8124, for procedures.

5 See Appendix B, "9729 Wiring and Power Plug Information" on page 79 for a simplified wiring diagram of the 9729 power circuitry.

DANGER

To avoid a shock hazard, do not connect or disconnect any cables or perform installation, maintenance, or reconfiguration of this product during an electrical storm.

DANGER

Before you connect the power cable of this product to ac power, verify that the power receptacle is correctly grounded and has the correct voltage.

If this 9729 has a redundant power system, as indicated by the presence of two ac power cords, read the following notice carefully:

DANGER

This unit has more than one power cord. To reduce the risk of electrical shock, disconnect both power supply cords prior to servicing.

Note: For translations of this safety notice, see Appendix A, “Translated Safety Notices” on page 65.

Safety Labels

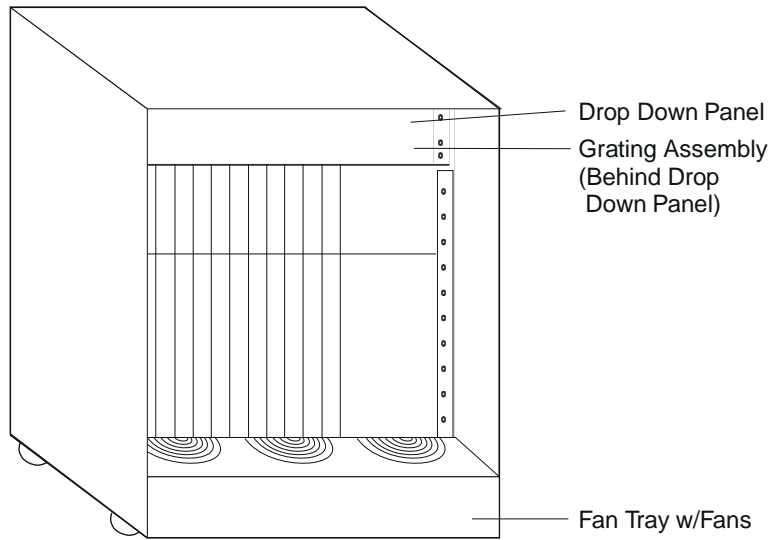

Front View

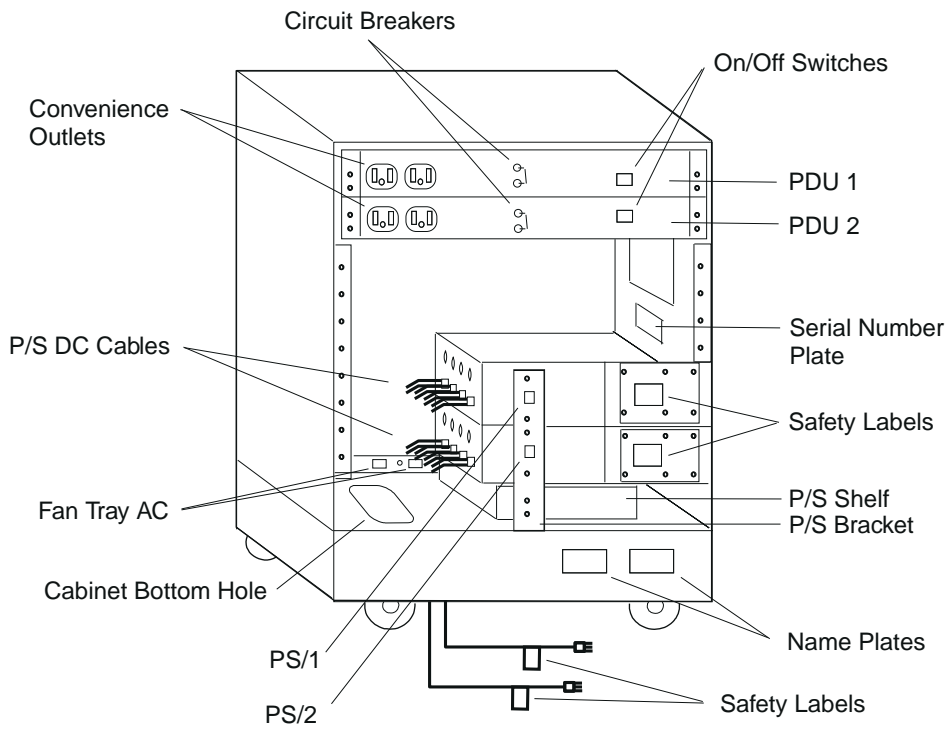

Rear View

安全检查过程

以下的过程指导IBM的维修代表如何确定IBM的产品是否符合IBM的安全及安装标准。每当你对产品的安全性提出质疑时，请做如下的检查。

向用户报告任何有损于产品安全性的缺陷。然后，在进行任何维修之前，改正这些缺陷，通过：

- 请按本页上本主题中的指导进行。
- 请使用本书中给出的信息，订购遗失和损坏的部件。

使用本页中的过程来检查以下的部件和功能：

1. 外部封装
2. 安全接地
3. 输入电源电压

注：请在切断电源的情况下实施以下过程。关闭电源并切断每个部件的电源。

1. 外部封装
检查：

- 每个部件上均贴有封套。
- 每个部件均有适当的空间并可供存取。

2. 安全标志
检查：

- 所有的安全标志均如本页的插图所示正确安置/S FLOC1/。
- 每个安全标志均如本页的插图所示/SAFLOC1/。

3. 接地

检查确定您的电源系统正确接地。正确的操作过程参考
Electrical Safety for IBM Customer Engineers, S229-8124.

4. 输入电源电压

检查并确定您的客户的电源插座提供线频率 50 至 60 Hz 的交流电，以及电压范围在 90 至 137 或 180 至 265 伏。正确的操作过程参考 *Electrical Safety for IBM Customer Engineers, S229-8124.*

危险

在电暴期间，为避免电击，请不要连接或断开任何电缆，或者对产品进行安装，维修或重新配置。

危险

在确保电源插座已正确地并处于正确的电压之后，您可以将产品的电缆与交流电相连。

Sicherheitsüberprüfungen

Anhand des nachfolgend beschriebenen Verfahrens kann der Kundendiensttechniker feststellen, ob das Produkt den IBM Sicherheits- und Installationsbestimmungen entspricht. Diese Überprüfungen vornehmen, falls die Sicherheit des Produkts in Frage gestellt wird.

Dem Eigner oder Benutzer alle Mängel melden, die die Sicherheit des Produkts beeinträchtigen. Vor jeder Wartungsarbeit diese Sicherheitsmängel folgendermaßen beheben:

- Die hier beschriebenen Sicherheitsüberprüfungen durchführen.
- Die fehlenden oder fehlerhaften Teile mit Hilfe der Angaben in diesem Handbuch bestellen.

Die Anweisungen auf dieser Seite verwenden, um die folgenden Teile und Funktionen zu prüfen:

1. äußere Abdeckungen
2. Sicherheitsaufkleber
3. Erdung
4. Eingangsspannung

Note: Vor der Durchführung der Sicherheitsüberprüfung den Netzschalter des Gerätes ausschalten und die Netzkabel jeder Einheit lösen.

1 ÄUßERE ABDECKUNGEN

Prüfen, ob

- die Abdeckung auf jeder Einheit vorhanden ist;
- in der Umgebung des Gerätes genügend Platz für Wartungsarbeiten vorhanden ist.

2 SICHERHEITSAUFKLEBER

Prüfen, ob

- alle Sicherheitsaufkleber an der richtigen Stelle (siehe Abbildung x auf Seite) angebracht sind und der
- Abbildung x auf Seite entsprechen.

3 ERDUNG

Prüfen, ob das Stromversorgungssystem vorschriftsmäßig geerdet ist. Siehe auch *Electrical Safety for IBM Customer Engineers*, IBM Form S229-8124.

4 EINGANGSSPANNUNG

Prüfen, ob die Stromversorgung des Kunden den elektrischen Anschlußspezifikationen entspricht: Wechselstrom mit einer Frequenz von 50 oder 60 Hz und einem Spannungsbereich von 200 bis 240 V. Siehe auch *Electrical Safety for IBM Customer Engineers*, IBM Form S229-8124.

DANGER

Aus Sicherheitsgründen bei Gewitter an diesem Gerät keine Kabel anschließen oder lösen. Ferner keine Installations-, Wartungs- oder Rekonfigurationsarbeiten durchführen.

DANGER

Produkt nur an eine ordnungsgemäß geerdete Steckdose mit der auf dem Gerät angegebenen Netzspannung anschließen.

Electronic Emission Notices

Federal Communications Commission (FCC) Statement

Note: This equipment has been tested and found to comply with the limits for a Class A digital device, pursuant to Part 15 of the FCC Rules. These limits are designed to provide reasonable protection against harmful interference when the equipment is operated in a commercial environment. This equipment generates, uses, and can radiate radio frequency energy and, if not installed and used in accordance with the instruction manual, may cause harmful interference to radio communications. Operation of this equipment in a residential area is likely to cause harmful interference, in which case the user will be required to correct the interference at his own expense.

Properly shielded and grounded cables and connectors must be used in order to meet FCC emission limits. IBM is not responsible for any radio or television interference caused by using other than recommended cables and connectors or by unauthorized changes or modifications to this equipment. Unauthorized changes or modifications could void the user's authority to operate the equipment.

This device complies with Part 15 of the FCC Rules. Operation is subject to the following two conditions: (1) this device may not cause harmful interference, and (2) this device must accept any interference received, including interference that may cause undesired operation.

Industry Canada Class A Emission Compliance Statement

This Class A digital apparatus meets the requirements of the Canadian Interference-Causing Equipment Regulations.

Avis de conformité aux normes d'Industrie Canada

Cet appareil numérique de la classe A respecte toutes les exigences du Règlement sur le matériel brouilleur du Canada.

European Community (CE) Mark of Conformity Statement

This product is in conformity with the protection requirements of EC Council Directive 89/336/EEC on the approximation of the laws of the Member States relating to electromagnetic compatibility. IBM cannot accept responsibility for any failure to satisfy the protection requirements resulting from a non-recommended modification of the product, including the fitting of non-IBM option cards.

This product has been tested and found to comply with the limits for Class A Information Technology Equipment according to CISPR 22/European Standard EN 55022. The limits for Class A equipment were derived for commercial and industrial environments to provide reasonable protection against interference with licensed communications equipment.

Warning: This is a Class A product. In a domestic environment this product may cause radio interference in which case the user may be required to take adequate measures.

Dieses Gerät ist berechtigt in Übereinstimmung mit dem deutschen EMVG vom 9.Nov.92 das EG-Konformitätszeichen zu führen. Der Aussteller der Konformitätserklärung ist die IBM:

IBM Spain Division of Fabrication
Carretera Valencia-Ademuz
46185 La Pobla de Vallbona (Valencia)

Dieses Gerät erfüllt die Bedingungen der EN 55022 Klasse A. Für diese Klasse von Geräten gilt folgende Bestimmung nach dem EMVG: Geräte dürfen an Orten, für die sie nicht ausreichend entstört sind, nur mit besonderer Genehmigung des Bundesministers für Post und Telekommunikation oder des Bundesamtes für Post und Telekommunikation betrieben werden. Die Genehmigung wird erteilt, wenn keine elektromagnetischen Störungen zu erwarten sind. (Auszug aus dem EMVG vom 9.Nov.92, Para.3, Abs.4)

Hinweis:

Dieses Genehmigungsverfahren ist von der Deutschen Bundespost noch nicht veröffentlicht worden.

Japanese Voluntary Control Council for Interference (VCCI) Statement

This equipment is in the 1st Class category (information equipment to be used in commercial and/or industrial areas) and conforms to the standards set by the Voluntary Control Council for Interference by Information Technology Equipment aimed at preventing radio interference in commercial and industrial areas. Consequently, when used in a residential area or in an adjacent area thereto, radio interference may be caused to radios and TV receivers, and so on.

Read the instructions for correct handling.

情報処理装置等電波障害自主規制協議会 (VCCI) 表示

この装置は、第一種情報装置(商工業地域において使用されるべき情報装置)で商工業地域での電波障害防止を目的とした情報処理装置等電波障害自主規制協議会(VCCI)基準に適合しております。

従って、住宅地域またはその隣接した地域で使用すると、ラジオ、テレビジョン受信機等に受信障害を与えることがあります。

取扱説明書に従って正しい取り扱いをして下さい。

Korean Communications Statement

Please note that this device has been approved for business purpose with regard to electromagnetic interference. If you find this is not suitable for your use, you may exchange it for a non-business purpose one.

대한민국 통신문

이 기기는 업무용으로 전자장해검정을 받은 II 이온기
X매자 또는 사용자는 이 점을 주의하시기 바라며, 만약 잘못
구입하였을 때에는 구입한 곳에서 비업무용으로 교환하시기 바랍니다.

Trademarks

The following terms are trademarks of the IBM Corporation in the United States or other countries or both:

ESCON

IBM

Other company, product, and service names may be trademarks or service marks of others.

About This Manual

This manual describes the installation, diagnostics, and replacement procedures for the IBM 9729 Optical Wavelength Division Multiplexer (9729).

Who Should Read This Manual

This manual is intended for the IBM service representative or other technical personnel responsible for the installation and maintenance of the 9729.

How This Manual Is Organized

This manual contains the following sections:

- Chapter 1, "Introduction" on page 1 contains an explanation of the 9729 front panel, a physical description, and cable specifications.
- Chapter 2, "Installation and Operation" on page 7 contains information on the installation and operation of the 9729.
- Chapter 3, "Troubleshooting Procedures" on page 11 contains troubleshooting procedures for the 9729.
- Chapter 4, "Removal and Replacement Procedures" on page 29 contains removal and replacement procedures for the components of the 9729.
- Appendix A, "Translated Safety Notices" on page 65 contains translated safety notices pertaining to the 9729.
- Appendix B, "9729 Wiring and Power Plug Information" on page 79 contains simplified wiring diagrams and other information relating to the 9729 power circuitry.

Chapter 1. Introduction

The IBM 9729 Optical Wavelength Division Multiplexer (9729) enables multiple bit streams, each possibly using a different communication protocol, bit rate, and frame format, to be multiplexed onto a single optical fiber for transmission between geographically separate locations. The 9729 can multiplex up to 10 full-duplex bit streams, each at up to 1 Gbps over a single optical fiber. The distance between the two locations can be up to 50 km (31 miles) at a 200-Mbps bit rate per channel, and goes down as the bit rate is increased. Thus the 9729 enables economical transmission of many simultaneous bit streams bidirectionally over a single fiber.

The 9729 uses wavelength division multiplexing to transmit independent bit streams over this single fiber link. A conventional optical fiber has an accessible bandwidth of 25 000 GHz, and wavelength division multiplexing uses as much of this bandwidth as possible. Each wavelength can carry a signal at any bit rate less than an upper limit defined by the electronics, typically up to several gigabits per second.

The 9729 is available in two models. The *Model 001* can divide a single fiber-optic line into as many as 20 separate channels and supports dual, fully-redundant power and cooling. The *Model 041* can divide a line into as many as eight separate channels; redundant power and cooling is optional. Throughout this manual, references to the 9729 are inclusive of both models; the model number will be used for information specific to a particular model.

Front Panel Reference

Refer to Figure 1 for the location of the indicators, switches, and connectors on the front panel.

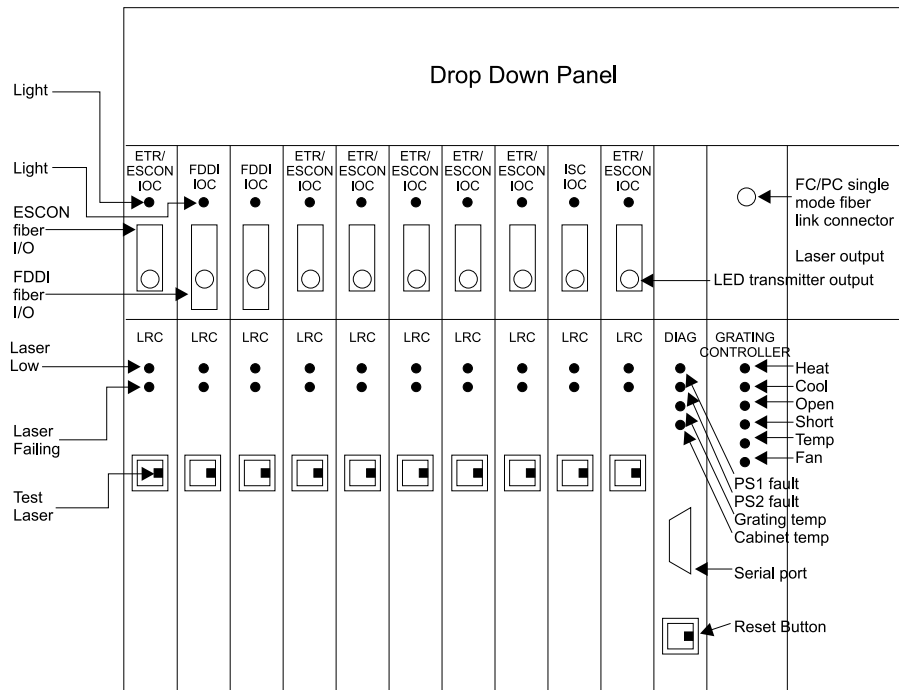

Figure 1. 9729 Front Panel Reference

Input/Output Controller (IOC) Indicators

- Green *Light* LED on each ESCON or ETR/ESCON IOC lights to indicate the presence of light
- Green *Light* LED on each FDDI IOC lights to indicate the presence of light
- Green *Light* LED on each inter-system coupling (ISC) IOC lights to indicate the presence of light.
- Amber *Fault* LED on each ISC IOC lights when a laser fault is detected.

Laser/Receiver Card (LRC) Indicators

- Amber *Laser Low* LED lights if laser has aged out of specification limits.
- Amber *Laser Fault* LED lights if laser control has failed and laser has been disabled
- Green *Ready* LED lights when a signal is being received from the corresponding card in the other box.

LRC Switch

Pressing the *Test Laser* button provides a reset to any LRC error indicated by an amber LED, and provides a backup method of establishing a connection with the other box on this channel. The diagnostic card provides the primary method of establishing the connection with the other box.

Diagnostic Card Indicators

Amber *PS 1 FAULT* LED lights if power supply 1 is defective or inoperative.
Amber *PS 2 FAULT* LED lights if power supply 2 is defective or inoperative
Amber *Grating Temp* LED lights if the grating temperature is out of range or if a grating controller fault occurs
Amber *Cabinet Temp* LED lights if the enclosure temperature is above normal
Green *Int* LED flashes on/off during normal operation of the diagnostic card

Diagnostic Card Switch

Pressing the Reset button restarts the processor on the diagnostic card. The **Int** LED blinks on and off when the processor on the diagnostic card is running.

Diagnostic Card Serial Port

Pin 2 Transmit
Pin 3 Receive
Pin 7 and pin 8 connected
Pin 5 Ground

TEC2 Card Indicators

Green *Heat* LED lights when a grating heating cycle is in progress
Green *Cool* LED lights when a grating cooling cycle is in progress
Amber *Open* LED lights when an open circuit is detected in the grating thermoelectric (TE) coolers.
Amber *Short* LED lights when a short circuit is detected in the grating thermoelectric (TE) coolers.
Amber *Temp* LED lights when the grating temperature is out of range
Amber *Fan* LED lights when a failure is detected in the grating fan

TEC Card Indicators

This card, while not shown in Figure 1 on page 2, can be found on some machines.

Green *Cool* LED lights when a grating cooling cycle is in progress
Amber *Heat* LED lights when a grating heating cycle is in progress

Dual Fiber I/O Card (if installed)

This feature, not shown in Figure 1 on page 2, may be installed on this machine.

Green *Primary* LED lights when the primary fiber is in use
Green *Secondary* LED lights when the secondary fiber is in use

Physical Description

- Operational environment: inside buildings only
 - Temperature:
 - Shipping and storage** 10–52°C (50–125°F)
 - Operating** 10–40°C (50–104°F)
 - Relative humidity: 5% to 95%
 - Power: dual redundant with two, country-dependent, alternative input voltages
 - 90–125 Volts, 6 Amps, 47–63 Hz
 - 180–264 Volts, 4 Amps, 47–63 Hz for Europe
- Note:** The 180 Volt version of the 9729 is supplied without a power plug. It is the customer's responsibility to provide the correct plug for their site. See Appendix B, "9729 Wiring and Power Plug Information" on page 79 for possible plug configurations.
- Physical dimensions:
 - Width** 600 mm (23.625 in.)
 - Depth** 645 mm (25.375 in.)
 - Height** 775 mm (30.5 in.)
 - Weight:
 - 109 kg (240 lb) for a fully configured Model 001
 - 91 kg (200 lb) for a fully configured Model 041 with a single power system
 - 102 kg (225 lb) for a fully configured Model 041 with a redundant power system
 - Heat dissipation:
 - 1500 watts for a 9729 with a redundant power system
 - 800 watts for a 9729 without a redundant power system

Cable Specifications

The following specifications for single-mode trunk cable support the attachment of fiber-optic channel-capable devices. Use of trunk fiber having different specifications significantly alters the link characteristics. These specifications conform to International Telecommunications Union (ITU) recommendation G.652.

All external fiber cabling should be in compliance with IEC 825-1:1993, "Safety of Optical Fiber Communication Systems".

The international equivalents to EIA test procedures are specified in ITU Recommendations G651 or G652. All these FOTPs are named EIA-455-xxx, where xxx is the FOTP number. Copies of the EIA documents can be obtained by writing to:

Director of Technical Programs
Information & Telecommunications Technologies
Electronic Industries Association
2001 I Street, NW
Washington, DC 20006

Characteristic	Value	Notes
Type of fiber	Dispersion unshifted	Dispersion shifted fiber may be used but is not recommended
Mode field diameter	9.0 - 10.0 $\mu\text{m} \pm 10\%$	Measured in accordance with EIA 455 FOTP 164,167 or equivalent
Core concentricity error	1.0 μm maximum	Meas. in acc. with EIA 455 FOTP 45,48
Cladding diameter	125 $\mu\text{m} \pm 2.0 \mu\text{m}$	Meas. in acc. with EIA 455 FOTP 45,48
Cladding noncircularity	2% maximum	Meas. in acc. with EIA 455 FOTP 45,48
Zero dispersion wavelength	1295 to 1322 nm	Meas. in acc. with EIA 455 FOTP 168 or equivalent
Zero dispersion slope	0.095 ps/(nm ² x km) maximum	Meas. in acc. with EIA 455 FOTP 168 or equivalent
Cutoff wavelength	1280 nm maximum	Meas. in acc. with EIA 455 FOTP 80 or equivalent
Cutoff wavelength	1260 nm maximum	Meas. in acc. with EIA 455 FOTP 170 or equivalent
Attenuation above nominal	0.06 dB/km maximum	Maximum attenuation for wavelengths from 1270 to 1340 nm must not exceed attenuation at 1310 nm by more than 0.06 dB/km. Typically, this specification can be met by fiber with 1383-nm OH absorption peaks below 2 dB/km.
Attenuation	0.2 dB/km maximum	This attenuation is a typical value, not a specification for wavelengths from 1540 to 1560 nm. Use actual dB/km attenuation value to determine the total link loss, which cannot exceed the value specified above.
Connector	FC/PC	
Maximum loss including connectors	15 dB at 1550 nm 13 dB at 1550 nm when ISC is installed 12 dB at 1550 nm when ISC and Dual Fiber SW are installed	

Chapter 2. Installation and Operation

- 1 Position the unit in place and lower the four leveling feet. See Figure 2 for space requirements and cable entry.

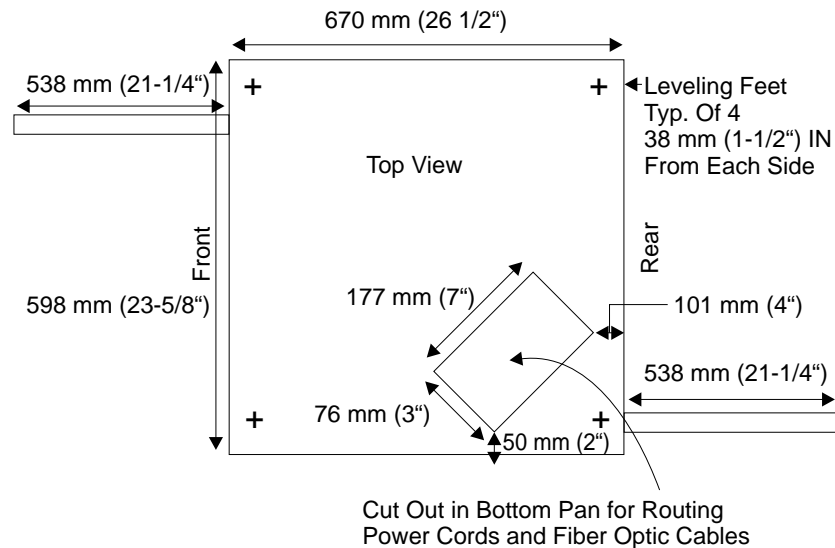

Figure 2. Physical Planning

- 2 Open the front door, remove the two screws at the top of the dropdown panel (see Figure 1 on page 2 for the location of the dropdown panel), and lower the panel. Keep the screws for future use.

3

Important

If this unit is a Model 001, it contains a redundant power system; it will have two ac plugs, two power distribution units (PDUs), two ac cables, and so on. If this unit is a Model 041, it may or may not contain a redundant power system. Verify whether or not this 9729 has a redundant power system before continuing with installation.

If this unit contains two power cords, they should run from different building ac power feeds. Open the rear door and pass the power cords from the ac power distribution units through the opening in the bottom panel.

- 4 **Attention:** To avoid fiber damage, use caution when routing cables near the fiber optics located at the top of the card cage and on the rear of the backplane.

Pull all fibers and the EIA 232 cable (for attaching a PC to the serial port) through the opening of the bottom panel and pass through the opening in the card cage to the open dropdown panel. Run fibers and cables through the cable guides on the back of the dropdown panel, allowing sufficient cable slack to close the panel.

- 5** Return the dropdown panel to its closed position and secure in place with the retaining screws that were previously removed.
- 6** Plug the EIA 232 cable into the serial port connector at the front of the diagnostic card. Clean all fiber optic connections with alcohol wipes. Plug the fiber connectors into the corresponding IOCs. Insert, align, and tighten the ferrule connector/physical contact (FC/PC) connector of the single-mode fiber links to the input/output connectors on the Fiber I/O Card or Dual Fiber I/O Card.
- 7** Ensure that the voltage provided matches the rating of the label located on the rear of the unit. Plug the two ac plugs into two separate feed lines. If this 9729 does not have redundant power, there is only one ac plug.
- 8** Switch on the circuit breakers on both PDUs. Verify that the green light labeled POWER on each PDU turns on. If this 9729 does not have redundant power, there is only one PDU.
- 9** Set the local/remote switch to LOCAL. The green light labeled SEQ1 should turn on immediately. After approximately 20 seconds, the green light labeled SEQ2 turns on.
- 10** Make sure that both ac cables to the fan tray are fully seated and that both the front and rear banks of fans are running. If this 9729 does not have redundant power, there will be only one ac cable.

Allow the grating temperature to stabilize for 20 minutes and then check that each LED indicator on the following cards is in its normal state.

diagnostic card

PS 1 Fault:	Off
PS 2 Fault:	Off
Grating Temp:	Off
Cabinet Temp:	Off
Int:	Flashing

IOCs

Light:	On (may require action to the attaching unit ¹)
Fault:	Off (ISC IOC only)

LRCs

Laser Low:	Off
Laser Fault:	Off

¹ The attaching device must be powered on and connected

Grating Assembly (Current)

Temp: Off
Short: Off
Fan: Off
Cool: Cycles on and off
Heat: Cycles on and off

Grating Assembly (Old)

Cool: Cycles on and off
Heat: Cycles on and off

11 Lock the rear door. Access to the rear door must be limited to service personnel. Store the keys in a safe place and document where they can be found for future maintenance activity.

12 When both ends of the link have been connected and allowed to stabilize, check that all “Ready” LEDs on the LRCs are on. If any LEDs are not on, see the applicable troubleshooting section in Chapter 3, “Troubleshooting Procedures” on page 11.

13 Obtain the link loss values from the customer and record them here:

Machine S/N:

Primary:

Secondary (if present):

Chapter 3. Troubleshooting Procedures

Use this chapter to isolate a problem with the 9729.

For convenience, the two units on a link are referred to as units A and B. To determine which unit is A and which is B, check the LRCs. The A unit will have the LRC designate Axx where xx is the slot number. The B unit LRCs will be designated Bxx.

Important

If this unit is a Model 001, it contains a redundant power system; it will have two ac plugs, two power distribution units (PDUs), two ac cables, and so on. If this unit is a Model 041, it may or may not contain a redundant power system. Verify whether or not this 9729 has a redundant power system before continuing with the troubleshooting procedures.

Required Test Equipment

The procedure you use in this chapter may require some of the following equipment:

- Optical power meter, P/N 12G8814 (contained in Field Test Support Kits, P/Ns 46G6837 and 46G6838)
- Alcohol wipes, P/N 9900679 (contained in Field Test Support Kits, P/Ns 46G6837 and 46G6838)
- LRC extender card, P/N 85H3526
- Coaxial cable removal tool, P/N 85H3527
- Optical Adapter removal tool, P/N 85H3528
- Dust cover removal tool, P/N 85H3536

The last four items are shipped as the 9729 Location Group Feature, which must be ordered by the customer.

Find the symptom exhibited by this 9729 in Table 1 and follow the procedure on the listed page.

Table 1. Trouble Symptoms

Symptom	Go To
All LEDs on front panel OFF	Page 12
PS1 or PS2 indicator ON	Page 14
Diagnostic card green Int LED not flashing	Page 16
Amber grating temp LED on diagnostic card ON	Page 17
Green ready LEDs OFF on all LRCs at both ends	Page 19
Primary and Secondary LEDs on Dual Fiber I/O Card ON	Page 19
Green ready LED flashing on LRC in unit A, OFF on LRC in unit B	Page 21
Green ready LED OFF on LRC in both unit A and unit B	Page 23
User device attached to a 9729 channel X logs an error	Page 24
IOC LED OFF	Page 25
SNMP monitor cannot access 9729	Page 25
Amber fan LED on Temperature Control (TEC) card ON	Page 17
Amber open LED on TEC card ON	Page 26
Amber short LED on TEC card ON	Page 27
Amber temp LED on TEC card ON	Page 26
Amber fault LED on ISC IOC ON	Page 27

All LEDs on Front Panel OFF

- 1** Check the Switched 1 and Power indicators on both PDUs. If this 9729 does not have a redundant power system, there is only one PDU.
 - If the indicators are ON, go to step 3.
 - If the indicators are OFF, continue with step 2.
- 2** Ensure that the circuit breakers on both PDUs are On, and that the Remote/Local switches on the PDUs are set to Local. If this 9729 does not have a redundant power system, there is only one PDU.
 - If the Switched 1 and Power indicators on either PDU are still OFF, verify that line voltage is present. If line voltage is present, replace the PDU using the instructions in “Removing and Replacing a Power Distribution Unit (PDU)” on page 45. Check the front panel LEDs again.
 - If the Switched 1 and Power indicators on both PDUs are now ON, and the front panel LEDs are still OFF, continue with step 3.
- 3** Make sure that the ac cord for each PDU is plugged in correctly and that the dc harness for each power supply is correctly connected to the backplane. If this 9729 does not have a redundant power system, there is only one ac cord and one dc harness.
- 4** If the front panel LEDs are still OFF, use the following procedure to check the four voltages at the backplane:
 - a** Remove the vertical front panel by removing the two retaining screws.

b Using a voltmeter, measure the dc supply voltages to the backplane (see Figure 3).

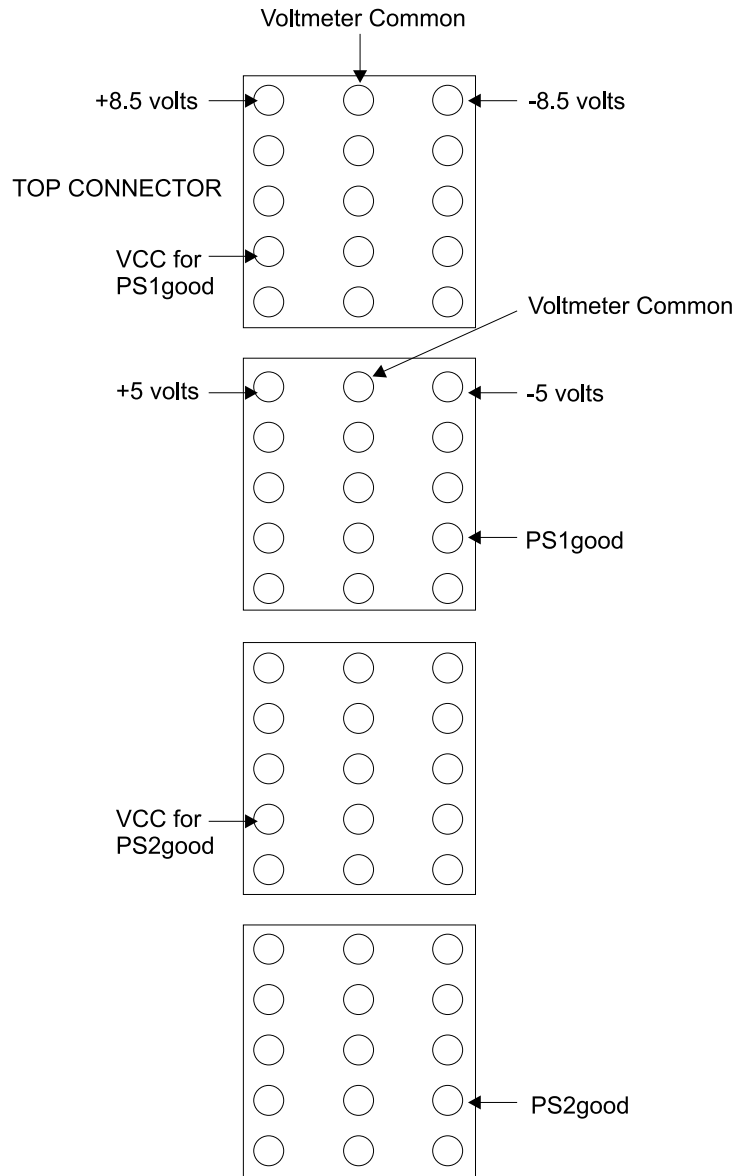

Figure 3. Backplane Connections Viewed from the Front

Note: If this 9729 does not have a redundant power system, voltages for a second power supply (PS2) will not be present.

5 If any of the voltages are not within 10% of specification, power off the system by switching the circuit breakers on both PDUs to Off; if this 9729 does not have a redundant power system, there is only one PDU. Continue with step 6.

If all voltages are within 10% of specification, go to step 7 on page 14.

6 Wait 20 seconds and then switch the circuit breakers on both PDUs to ON; if this 9729 does not have a redundant power system, there is only one PDU. If the LEDs on the front panel are now ON, the problem may have been a

power line overvoltage condition that shut off both supplies. It may be necessary to add additional line protection equipment to prevent this problem from recurring.

- 7** If the front panel LEDs are still OFF and this 9729 does not have a redundant power system, contact IBM support.

If this 9729 does have a redundant power system, power the 9729 off again and recheck the power supply voltages using the following procedure:

- a** Remove the harness for one power supply from the backplane and switch the circuit breaker on the PDU corresponding to the remaining power supply to On.
- b** Recheck the voltages. If any voltage is not within 10% of specification, replace the power supply following the procedure in “Removing and Replacing a Power Supply” on page 48. power the system on, and check the front panel LEDs again.
- c** Repeat this procedure for the other power supply, replacing it if necessary.

- 8** If none of these steps solves the problem, contact IBM support.

PS1 or PS2 Indicator ON on Diagnostic Card

- 1** Ensure that the line cords are plugged into power outlets and that ac power is present at the outlet. If this 9729 does not have a redundant power system, there is only one line cord.
- 2** If ac power is present at the outlet and the line cords are plugged in, ensure that the dc power supplies are plugged into the PDU. If this 9729 does not have a redundant power system, there is only one dc power supply.
 - If the dc power supplies are plugged in, continue with step 3.
 - If the dc power supplies are not plugged in, plug them in and recheck the indicator.
- 3** Check the Switched 1 and Power indicators on PDU1 (for PS1) or PDU2 (for PS2). If this 9729 does not have a redundant power system, there is only one PDU.
 - If these indicators are ON, go to step 5 on page 15.
 - If they are OFF, continue with step 4
- 4** Ensure that the circuit breakers on the PDU are on and that the Remote/Local switch on the PDU is set to Local.
 - If the indicators are still off, replace the PDU using the procedure in “Removing and Replacing a Power Distribution Unit (PDU)” on page 45, and recheck the LEDs.
 - If the indicators are now on and the diagnostic card LED is still on, go to step 5 on page 15.

5 Ensure that the dc harness for the power supply is connected to the backplane.

- If it is not, connect it and recheck the indicator. If the indicator is still on, continue with step 6.
- If it is, continue with step 6.

6 Check the dc voltages at the backplane using Figure 3 on page 13.

- If the dc voltages are within 10% of specification, replace the diagnostic card using the procedure in “Removing and Replacing the Diagnostic Card” on page 35.
- If the dc voltages are not within 10% of specification, replace the dc power supply using the procedure in “Removing and Replacing a Power Supply” on page 48.

If none of these procedures corrects the problem, contact IBM support.

Diagnostic Card Green Int LED Not Flashing

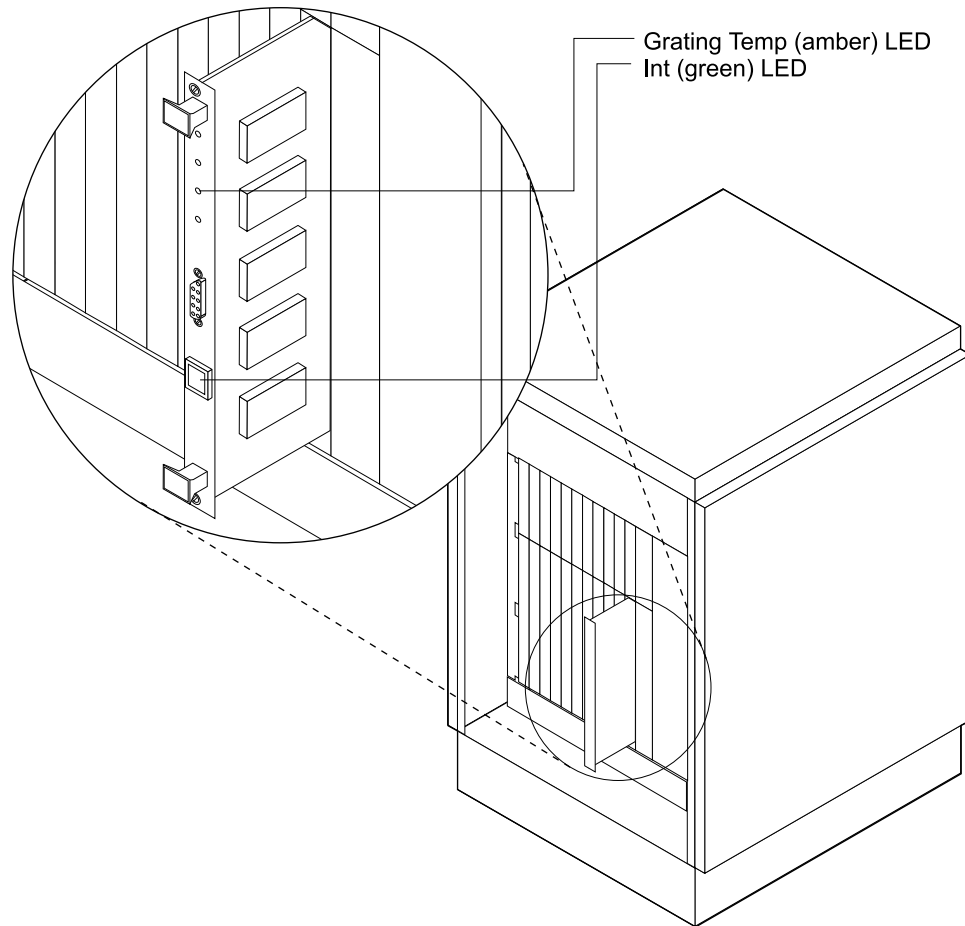

Figure 4. diagnostic card LEDs

- 1** Press the Reset button on the diagnostic card and see if the LED now flashes. If the LED does not flash, continue with step 2.
 - 2** Remove the diagnostic card from the machine using the instructions in “Removing and Replacing the Diagnostic Card” on page 35. Check that jumper JP1 is in position 1 and JP2 is in position 2 using Figure 16 on page 37.
 - 3** Check the voltages at the backplane (see Figure 3 on page 13).
 - 4** If the voltages are correct, replace the diagnostic card (see “Removing and Replacing the Diagnostic Card” on page 35).
- If the voltages are not correct, check the dc voltages at the backplane using Figure 3 on page 13.
- If the dc voltages are within 10% of specification, replace the diagnostic card using the procedure in “Removing and Replacing the Diagnostic Card” on page 35.

- If the dc voltages are not within 10% of specification, replace the dc power supply using the procedure in “Removing and Replacing a Power Supply” on page 48.

Amber Grating Temp LED on Diagnostic Card ON

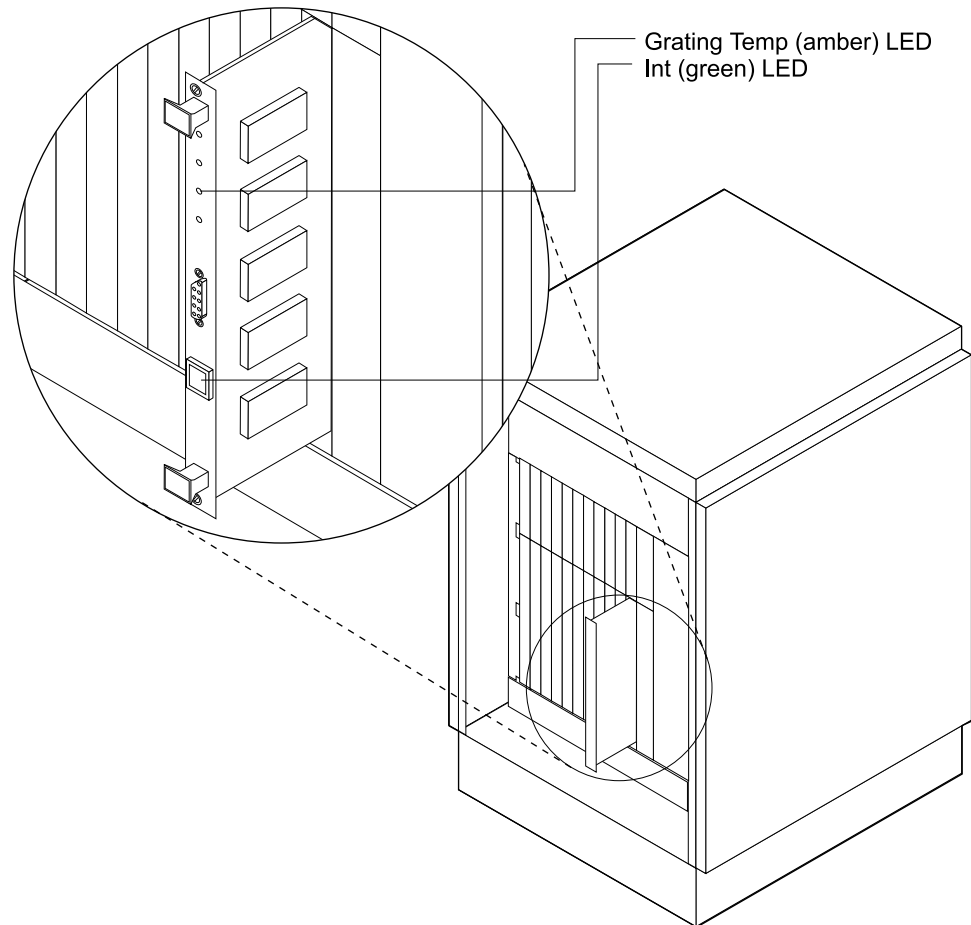

Figure 5. Diagnostic Card LEDs

- 1** Check ambient temperature and see if it is within allowable limits (10°–40° C [50°–104° F]).
- 2** If this 9729 has the old TEC card (identified by two LEDs on the front panel), continue with the next step. If this 9729 has the new TEC2 card (identified by six LEDs on the front panel), check the fault indicators on the card.
 - If a fault indicator is on, return to Table 1 on page 12 and go to the diagnostic procedure for that indicator.
 - If no fault indicator on the TEC card is on, continue with step 3.
- 3** Check the grating fan to see if it is operational. Replace it if required, using the instructions in “Replacing the Grating Fan” on page 60. If the problem still is not corrected, continue with step 4 on page 18.

- 4** Unplug the TEC card and plug it back in.
- 5** If the indicator does not turn off and remain off:
 - a** Replace the TEC card using the instructions in “Removing and Replacing the TEC Card” on page 38.
 - b** If the amber grating temp LED is still on, replace the diagnostics card using the instructions in “Removing and Replacing the Diagnostic Card” on page 35.
- 6** Check the grating electrical connectors to see if they are seated correctly.
- 7** Power the unit off and power it back on. Do this by switching the white circuit breaker on PDU 1 and PDU 2 to the OFF position for approximately 1 minute, and then switching the circuit breakers on PDU 1 and PDU 2 to ON. If this 9729 does not have a redundant power system, there is only one PDU.
- 8** If none of these steps fixes the problem, replace the grating assembly (see “Removing and Replacing the Grating Assembly” on page 41).

Green Ready LEDs OFF on All LRCs at Both Ends, or Primary & Secondary LEDs on Dual Fiber I/O Card Toggling On and Off

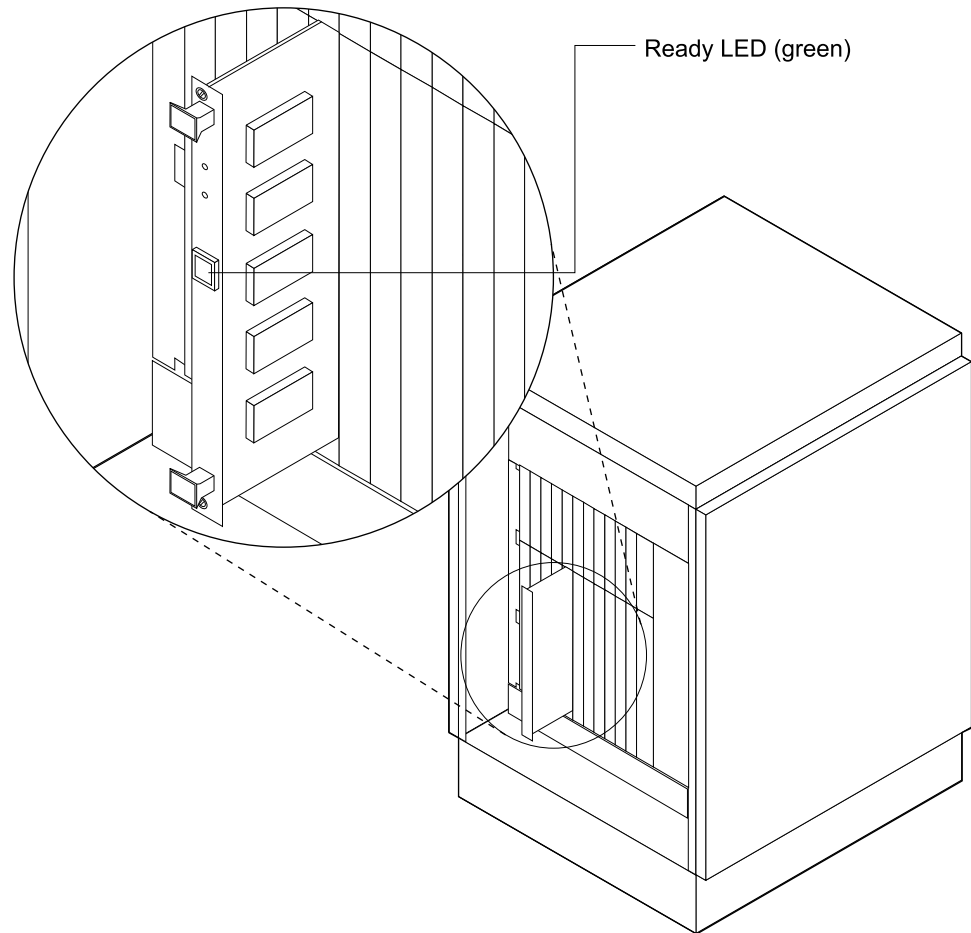

Figure 6. LRC LED

1 If the system has a single-fiber card, continue with step 2 on page 20.

At both ends of the connection:

a Check the primary and secondary LEDs on the Dual Fiber I/O Card.

- If they are switching between primary and secondary on both units, ensure that the loss on the primary and secondary fibers and all patch panel connectors total less than 15 dB (12 dB if the system contains any ISC channels).
- If they are not switching, check the green *Int* LED on the diagnostic card. If it is flashing, reset the card. If the LED still does not flash, remove the card using the instructions in “Removing and Replacing the Diagnostic Card” on page 35. Using Figure 16 on page 37, make sure that the jumpers are correctly installed. If the jumpers are correctly installed, replace the card.

b Check the fiber mode setting using the SNMP console.

- If the fiber mode is AUTO, replace the fiber card using the instructions in “Removing and Replacing the Fiber I/O Card or Dual Fiber I/O Card” on page 40.
- If the fiber mode is not AUTO, set it to AUTO. If the problem persists, replace the Dual Fiber I/O Card.

2 If possible, check the integrity of the link between the units, paying special attention to:

- Sharp kinks or bends; remove them
- Loose connections in the link
- Correct connection at any patch panels enroute

If you encounter difficulties in the link or are unable to check the link yourself, contact the link provider.

3 Ensure that the power cables are connected. If this 9729 does not have a redundant power system, there is only one power cable.

4 Check the Grating Temp LED on the diagnostic card. If it is ON, go to the appropriate TEC card diagnostic procedure in Table 1 on page 12; otherwise, continue with step 5.

5 Isolate the problem by unplugging the fiber on the link at one unit and measuring the incoming optical power on the fiber.

- If the received optical power is > -39 dBm (-31 dBm if an ISC IOC is installed), the problem is in the receiving unit.
- If the received optical power is < -39 dBm, the problem is in the sending unit.
- If the received optical power on both units is < -39 dBm (-31 dBm if ISC is installed), check the integrity of the link. If the link integrity is acceptable, perform the procedures in step 6 for each unit.
- If the received optical power on both units is > -39 dBm (-31 dBm if ISC is installed), perform the procedures in step 6 for each unit.

6 Once the problem has been localized on the affected unit:

a Clean the optical contacts on the fiber I/O card with alcohol wipes.

If the problem continues, replace the card using the instructions in “Removing and Replacing the Fiber I/O Card or Dual Fiber I/O Card” on page 40. If the problem persists, continue with step 6b.

b Replace the optical adapter in the fiber I/O slot using the procedure in “Removing and Replacing Optical Adapters” on page 43. If the problem persists, consult your local support structure.

Green Ready LED Flashing on LRC in Unit A while OFF on Corresponding LRC in Unit B

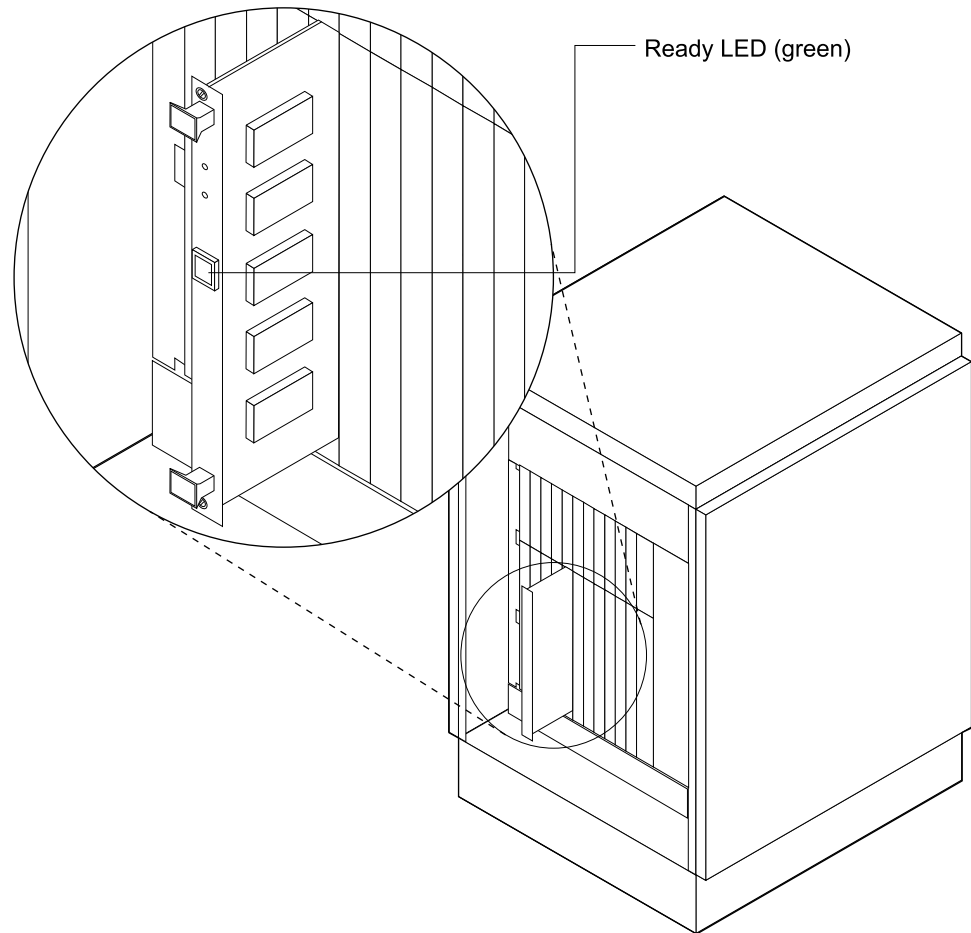

Figure 7. Laser-Receiver Card LED

- 1** Verify that the Laser Low and Laser Fault LEDs on both LRCs are OFF. If either of these LEDs is ON, replace the indicated LRC. If the problem persists, continue with step 2.
- 2** Remove the LRCs using the instructions in “Removing and Replacing an LRC” on page 34. Clean the fiber optic contacts on the cards with alcohol wipes. Reinstall them in the card cage. If the problem persists, continue with step 3.
- 3** Remove the IOC connector for the affected channel from unit A using the instructions in “Removing and Replacing an IOC” on page 39. Verify that the Light LED turns OFF.
 - If it does, continue with step 4 on page 22.
 - If it does not, replace the IOC and recheck the Light LED.

4 With the IOC connector removed for the affected channel in unit A and the Light LED off, check the Ready LED on the LRC for the affected channel in unit A.

- If the Ready LED turned on, continue with step 5.
- If the Ready LED did not turn on, go to step 8.

5 Replace the IOC if you have not already done so.

6 Check the coaxial cables on the backplane of unit A connecting the IOC to the LRC.

- If they are connected correctly, replace the LRC.
- If they are not connected correctly, connect them correctly.

Continue with step 7.

7 Recheck the LEDs.

- **If the LEDs are correct, you have completed the procedure.**
- If the LEDs are not correct, continue with step 8.

8 Put the LRC on the extender card and add a jumper to the MOD position on the card (see Figure 14 on page 35 for the jumper locations).

- If the LRC Ready LED turns on, continue with step 9.
- If the LRC Ready LED does not turn on, go to step 10.

9 Two problems exist (the IOC Light LED is not working, and there is no data). In this case:

a Remove the MOD jumper from the LRC.

b Repeat the IOC connector test beginning at step 3 on page 21.

10 Measure the laser output power at the extender's fiber coupler labeled TI.

- If it is < -17 dBm (-15 dBm for the newer LRCs), install a replacement LRC.
- If it is > -17 dBm, remove the MOD jumper, reinstall the LRC, and continue with step 11.

11 In unit B:

Place the LRC on the extender card and measure the received optical power using the procedure in "Measuring Received Optical Power and Tuning LRC Wavelength" on page 30.

- If the power is > -39 dBm (-31 dBm if an ISC IOC is installed), the problem is likely to be an LRC in one of the units. Replace both LRCs for the affected channel.
- If the power is < -39 dBm (-31 dBm if an ISC IOC is installed), and the problem persists, consult your local support structure.

Green Ready LED OFF on LRC in Both Unit A and Unit B

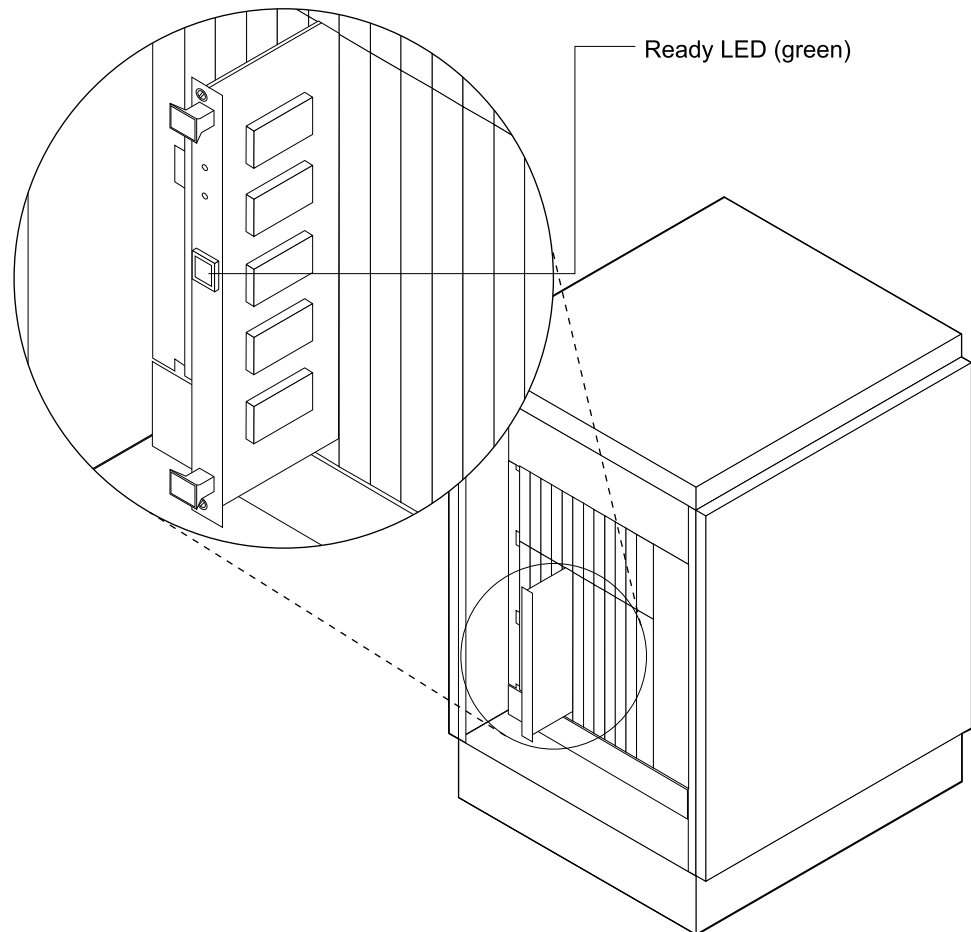

Figure 8. Laser/Receiver Card LED

- 1** Check the Laser Low and Laser Fault LEDs on both LRCs.
 - If either of these indicators is on, replace that LRC using the instructions in “Removing and Replacing an LRC” on page 34. Recheck the Ready LEDs.
 - If these indicators are OFF, continue with step 2.
- 2** Remove the LRCs and clean the fiber contacts on the cards with alcohol wipes. Reinstall the LRCs and recheck the LEDs. If the problem persists, continue with step 3.
- 3** Measure the incoming optical power at LRC B using the procedure in “Measuring Received Optical Power and Tuning LRC Wavelength” on page 30.
 - If the power is < -39 dBm (-31 dBm if an ISC IOC is installed), LRC B is OK. Adjust the wavelength of LRC A using the procedure in “Measuring Received Optical Power and Tuning LRC Wavelength” on page 30 and recheck the LEDs. If the problem persists, continue with step 4 on page 24.

- If the power is > -39 dBm (-31 dBm if an ISC IOC is installed), replace LRC B and recheck the LEDs. If the problem persists, continue with step 4 on page 24.
- 4** Measure the incoming optical power at LRC A using the procedure in “Measuring Received Optical Power and Tuning LRC Wavelength” on page 30.
- If the power is < -39 dBm (-31 dBm if an ISC IOC is installed), LRC A is OK. Adjust the wavelength of LRC B using the procedure in “Measuring Received Optical Power and Tuning LRC Wavelength” on page 30 and recheck the LEDs. If the problem persists, consult your local support structure.
 - If the power is > -39 dBm (-31 dBm if an ISC IOC is installed), replace LRC A and recheck the LEDs. If the problem persists, consult your local support structure.

Device Attached to a 9729 Channel X Logs an Error

- 1** Determine if the 9729 is at fault by removing the connectors from both IOCs of channel X and connecting them to another 9729 channel, channel Y, that is currently operational.
- If the attached end equipment still logs an error, the problem is unlikely to be in the 9729.
 - If the attached end equipment does not log an error, continue with step 2.
- 2** Replace the IOCs at both ends of channel X using the instructions in “Removing and Replacing an IOC” on page 39.
- 3** Check the LRC Ready LEDs in units A and B. If they are ON, tune the laser wavelengths on the LRCs in both units using the procedure in “Measuring Received Optical Power and Tuning LRC Wavelength” on page 30. If the problem persists, continue with step 4.
- 4** Measure the received optical power into LRC A.
- If the power is < -39 dBm (-31 dBm if an ISC IOC is installed), replace LRC B using the instructions in “Removing and Replacing an LRC” on page 34. If the problem persists, continue with step 5.
 - If the power is > -39 dBm (-31 dBm if an ISC IOC is installed), continue with step 5.
- 5** Measure the received optical power into LRC B.
- If the power is < -39 dBm (-31 dBm if an ISC IOC is installed), replace LRC A. If the problem persists, consult your local support structure.
 - If the power is > -39 dBm (-31 dBm if an ISC IOC is installed), the problem is unlikely to be in the 9729.

IOC Light LED OFF

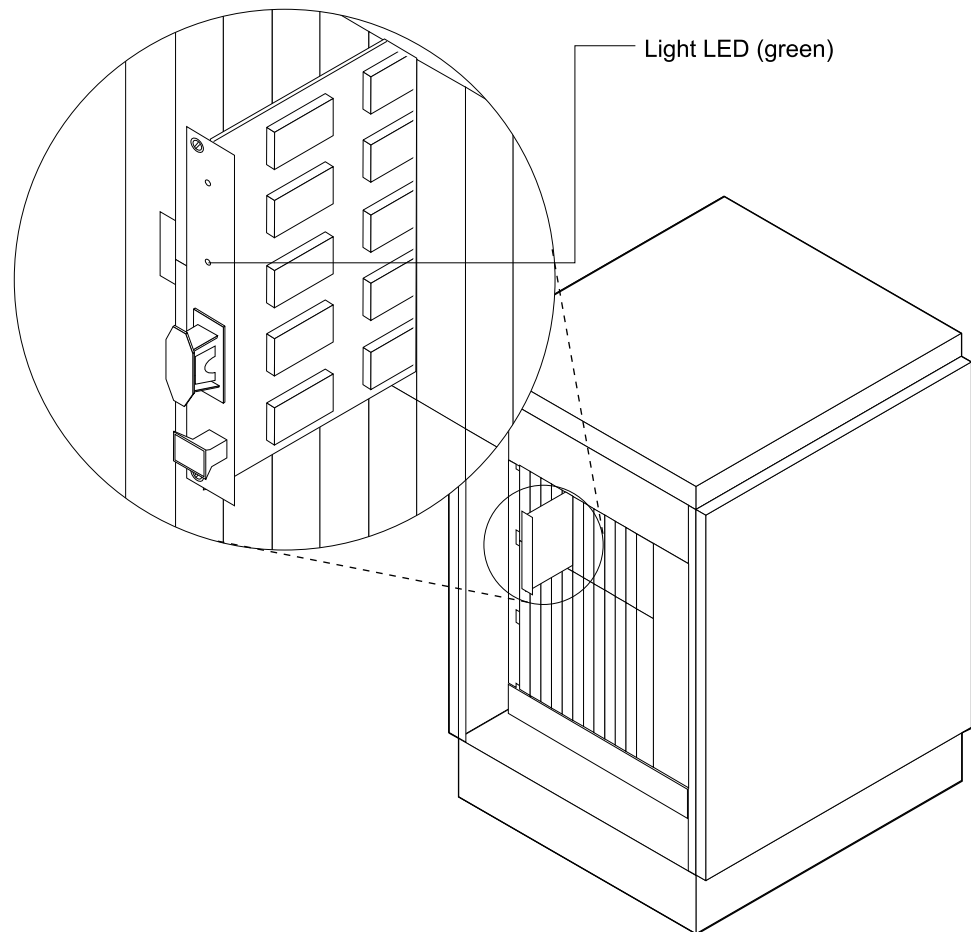

Figure 9. IOC LED

- 1** Verify that the connector is correctly seated in the IOC.
- 2** Verify that the device connected to the port is active.
- 3** Verify that no breaks or kinks exist in the fiber or coaxial cable.
- 4** Verify that the coaxial cable and fibers, if applicable, are not reversed.
- 5** Replace the IOC using the instructions in “Removing and Replacing an IOC” on page 39.

SNMP Monitor Cannot Access the 9729

- 1** Verify that the SNMP monitor is installed on the PC and is operating.
- 2** Verify that the EIA 232 cable is correctly plugged into the diagnostic card front panel connector and the PC.

- 3** Verify that the diagnostic card Int LED is flashing. If it is not, push the **Reset** button on the diagnostic card.
- 4** If the SNMP monitor still cannot access the 9729, replace the diagnostic card using the instructions in “Removing and Replacing the Diagnostic Card” on page 35.

Amber Temp LED on TEC Card ON

- 1** Ensure that the ambient temperature of the room is within the limits specified for the 9729.
 - If it is, replace the TEC card using the instructions in “Removing and Replacing the TEC Card” on page 38.
 - If it is not, notify the customer.
- 2** Ensure that the grating fan is operating.
 - If it is not, replace it using the instructions in “Replacing the Grating Fan” on page 60.
 - If it is, continue with step 3.
- 3** Ensure that the wiring harness from the grating enclosure is plugged into the backplane connector.
 - If it is, continue with step 4.
 - If it is not, connect it.
- 4** If the LED remains on, replace the diagnostic card using the instruction in “Removing and Replacing the Diagnostic Card” on page 35.
- 5** Power the unit off and back on.

Amber Open LED on TEC Card ON

- 1** Remove and reseat the TEC card using the instructions in “Removing and Replacing the TEC Card” on page 38.
- 2** If the LED remains on, check the electrical connectors to the grating to ensure that they are seated correctly.
- 3** Power the unit off and back on.
- 4** If the LED remains on, replace the TEC card and diagnostic card (see “Removing and Replacing the Diagnostic Card” on page 35).
- 5** If none of these steps works, replace the grating assembly using the instructions in “Removing and Replacing the Grating Assembly” on page 41.

Amber Short LED on TEC Card ON

- 1** Remove and reseal the TEC card.
- 2** Check the electrical connectors to the grating to ensure that they are seated correctly.
- 3** Power the unit off and back on.
- 4** If the LED remains on, replace the TEC card and diagnostic card (see “Removing and Replacing the Diagnostic Card” on page 35).
- 5** If none of these steps works, replace the grating assembly using the instructions in “Removing and Replacing the Grating Assembly” on page 41.

Amber Fault LED on ISC IOC ON

- 1** Determine if the 9729 is at fault by removing the connectors from both ISC IOCs of the affected channel and connecting them to another 9729 channel that is currently operational.
 - If the end equipment still logs an error, it is unlikely that the problem is in the 9729.
 - If the end equipment does not log an error, continue with step 2.
- 2** For the affected channels, replace the IOCs on both ends using the instructions in “Removing and Replacing an IOC” on page 39.
- 3** If the Ready LEDs in units A and B are off, tune the laser wavelength on the LRCs in both units using the procedure described in “Measuring Received Optical Power and Tuning LRC Wavelength” on page 30.
- 4** If the end equipment still logs an error, measure the received optical power into the LRCs. If the input power into the LRCs is ≥ -31 dBm., it is unlikely that the problem is in the 9729.

Chapter 4. Removal and Replacement Procedures

Use the procedures in this chapter any time you are removing or replacing a 9729 component.

Note: The procedures in this manual should be performed only by qualified service personnel.

Required Test Equipment

The procedure you use in this chapter may require some of the following equipment:

- Optical power meter, P/N 12G8814 (contained in Field Test Support Kits, P/Ns 46G6837 and 46G6838)
- Alcohol wipes, P/N 9900679 (contained in Field Test Support Kits, P/Ns 46G6837 and 46G6838)
- LRC extender card, P/N 85H3526
- Coaxial cable removal tool, P/N 85H3527
- Optical Adapter removal tool, P/N 85H3528
- Dust cover removal tool, P/N 85H3536

The last four items are shipped as the 9729 Location Group Feature, which must be ordered by the customer.

Note: Some of the following procedures require service personnel at both ends of the link.

Periodic Maintenance

The following maintenance must be performed on the 9729 once a year.

- Tune each LRC to compensate for any wavelength drift over the year. See “Measuring Received Optical Power and Tuning LRC Wavelength” on page 30 for instructions.
- Replace the filter under the fan tray. See “Removing and Replacing the Fan Filter” on page 53 for instructions.

Both these procedures can be done while the 9729 is powered on.

Measuring Received Optical Power and Tuning LRC Wavelength

This procedure requires service personnel at both ends of the link with an LRC extender card and optical power meter.

- 1 Open the front door and remove the LRC by loosening the screws at the top and bottom, and then pulling the top and bottom card ejectors simultaneously.
- 2 Remove the card from the unit and temporarily place it on a clean surface where it will not be damaged.
- 3 Using alcohol wipes, clean the optic connectors of the slot from which you removed the LRC.
- 4 Install the LRC extender card into the slot.
- 5 Remove the fiber jumper from the LRC extender card connection labeled "RO" and attach it to an optical power meter set to 1550 nm.
- 6 Install the LRC on the channel where the received power must be measured onto an extender card as shown in Figure 10.

LASER adjustment setup

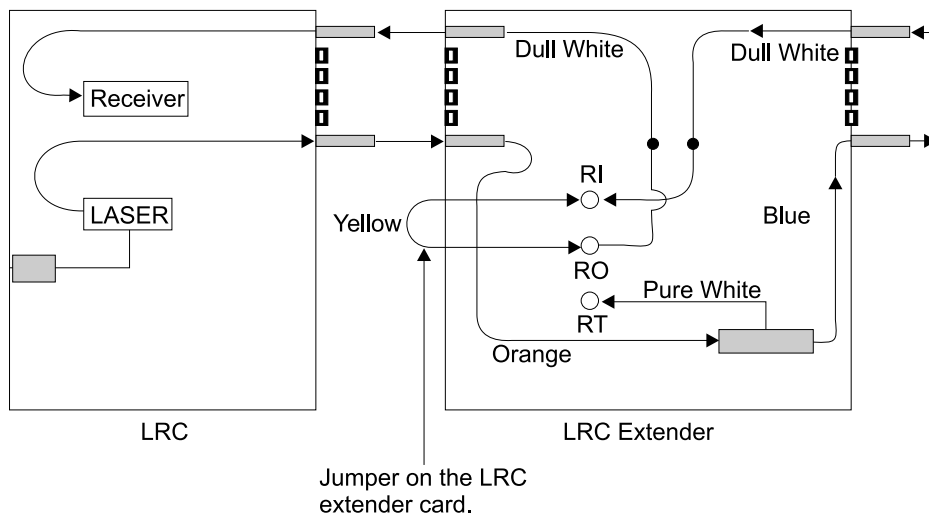

Figure 10. Laser Adjustment Setup

- 7 Remove the fiber jumper from the extender card connector labeled RO and attach the fiber to an optical power meter set to 1550 nm.
- 8 Ask the person at the other end to press the Test Laser button on the LRC while you read the power meter at this end.

If a source of data is not available at the other end (IOC Light is off), then the person at that end must remove the LRC, install the MOD and Test jumpers, and reinstall the LRC.

If a wavelength requires adjustment, the person at the other end turns the wavelength potentiometer until you read the maximum power level at this end. The wavelength potentiometer is adjusted through a small hole in the LRC front panel.

The potentiometer adjustment normally requires less than one full turn in either direction. It should be turned slowly to allow adequate time for the optical meter to reflect the new values.

Note: Hold down the Test Laser button during the wavelength adjustment unless the Test jumper was installed.

- 9** Ask the person at the other end to remove the jumpers (if they were installed on the LRC at that end) and reinstall the LRC.
- 10** Remove the LRC extender card from this end and reinstall the previously removed LRC.
- 11** If the wavelength for the LRC at this end also needs to be adjusted, then reverse this procedure and adjust its wavelength.
- 12** Tighten the two screws to secure the LRC in place. Verify that the green Ready LED turns on and remains on.
- 13** Close the front door of the unit.

Removing and Replacing a Generic Card

Note: This procedure applies to the removal and replacement of all cards in the 9729. Before replacing a card, read the specific procedures that apply to that card:

- “Removing and Replacing an LRC” on page 34
- “Removing and Replacing the Diagnostic Card” on page 35
- “Removing and Replacing the TEC Card” on page 38
- “Removing and Replacing an IOC” on page 39
- “Removing and Replacing the Fiber I/O Card or Dual Fiber I/O Card” on page 40

- 1** Open the front panel and locate the card to be replaced.

2 Loosen the top and bottom panel locking screws. The screws are not removable, but will loosen and be retained by the plastic sleeve.

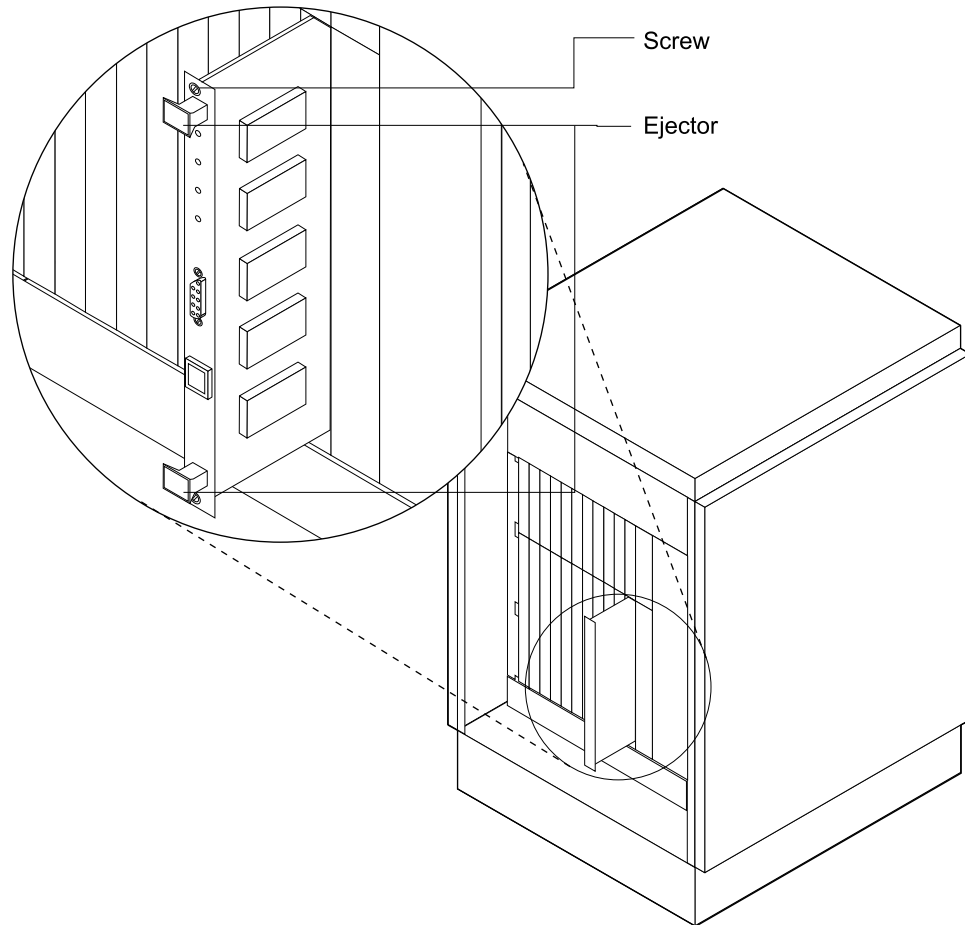

Figure 11. Generic Card Removal from Bottom Row

- 3 Unplug the card by simultaneously lifting the top ejector lever and lowering the bottom ejector lever, and slowly slide the card out.

Note: Cards in the top row have only bottom ejectors. Lower this ejector and carefully slide the card out.

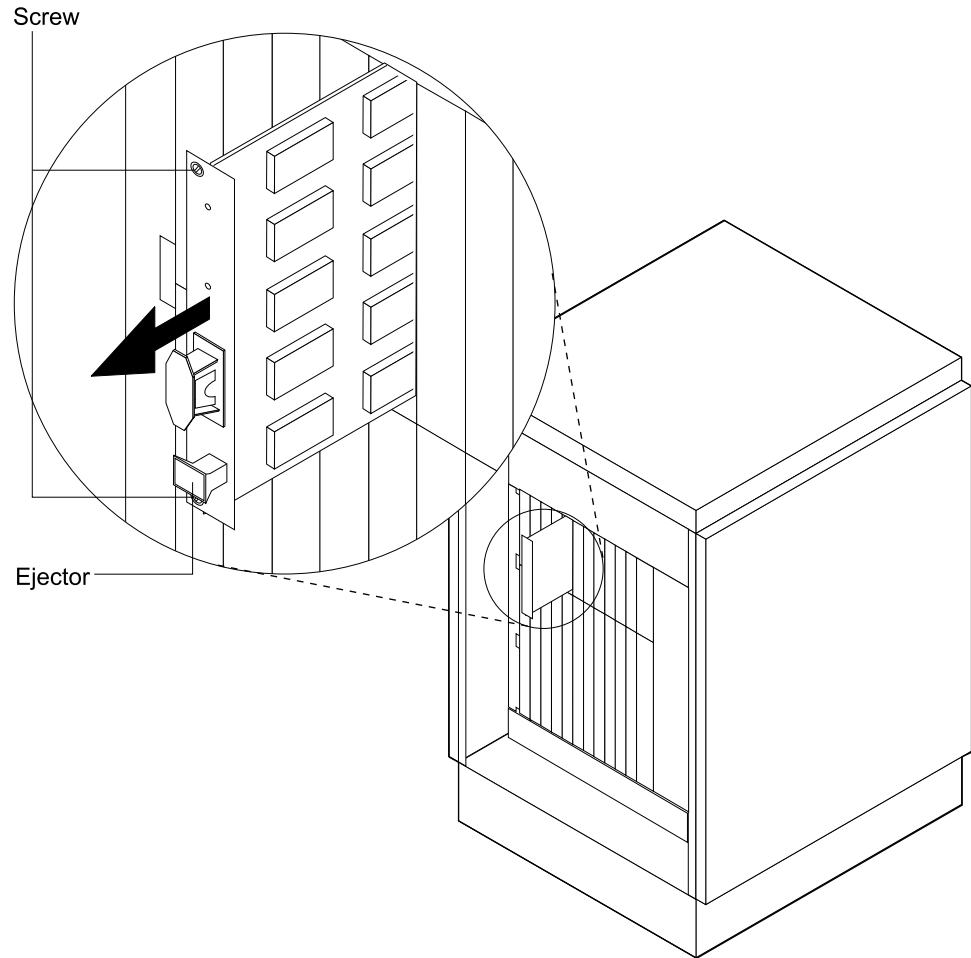

Figure 12. Generic Card Removal from Top Row

- 4 Remove the replacement card from its protective ESD bag.
- 5 Carefully align the top and bottom of the replacement card with the plastic guides in the slot opening.
- 6 Gently slide the card into the slot until it touches the backplane connector, and then seat the card by pressing firmly on the front panel just below the top ejector and just below the bottom ejector.
- 7 Tighten the top and bottom panel locking screws.

Removing and Replacing an LRC

This procedure requires the use of the LRC extender card and optical power meter.

An LRC can be removed or inserted at any time while the unit is powered on, without affecting the other channels. Replacement of an LRC requires tuning to the correct wavelength. See “Measuring Received Optical Power and Tuning LRC Wavelength” on page 30.

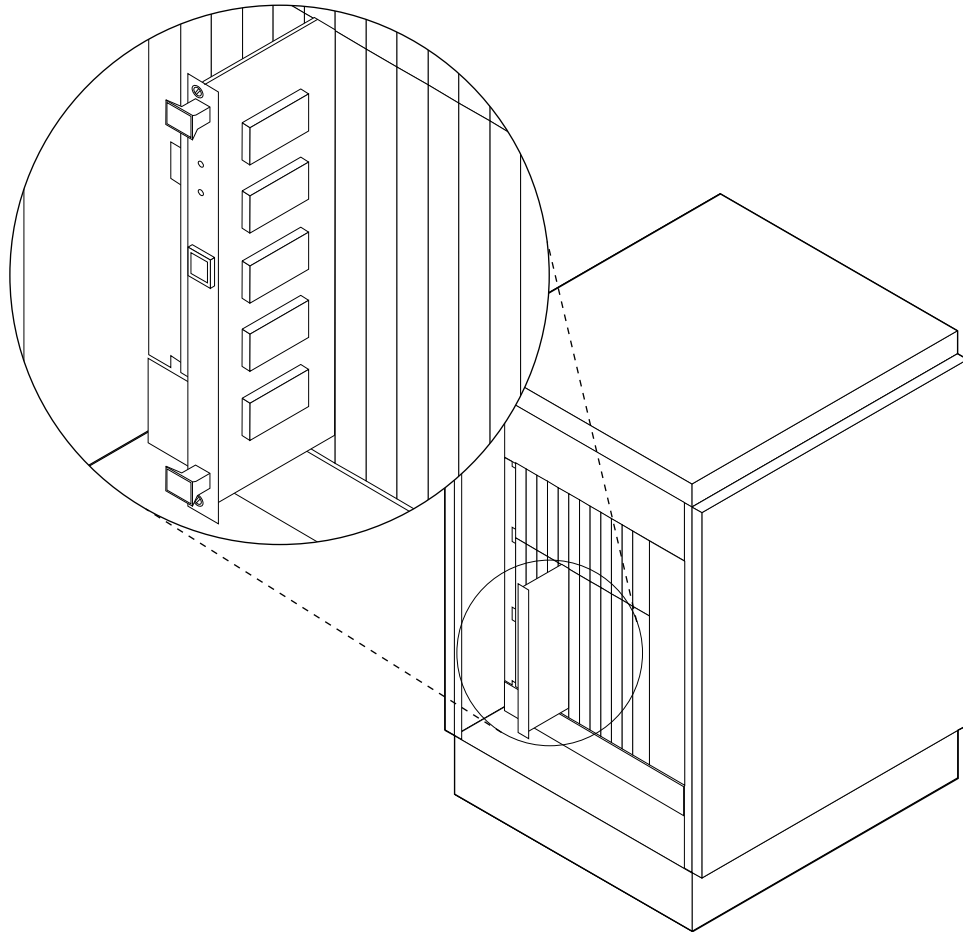

Figure 13. LRC Removal and Replacement

- 1** Remove the LRC using the procedure in “Removing and Replacing a Generic Card” on page 31.
- 2** Remove the replacement card from its ESD-protective bag, remove the two tip protectors from the DIN fiber connectors, and clean the fiber connectors with alcohol wipes. Inspect the fiber connectors and guide pins for any possible damage (scratches, foreign matter, chipping, or bending). Do not install if any damage is suspected.

- 3 Move the jumper blocks from the card you have removed to the card you are installing. Position the jumpers on the new card in the same positions as on the card you are replacing. See Figure 14 for the location of the jumpers.

LRC Card Jumper Locations

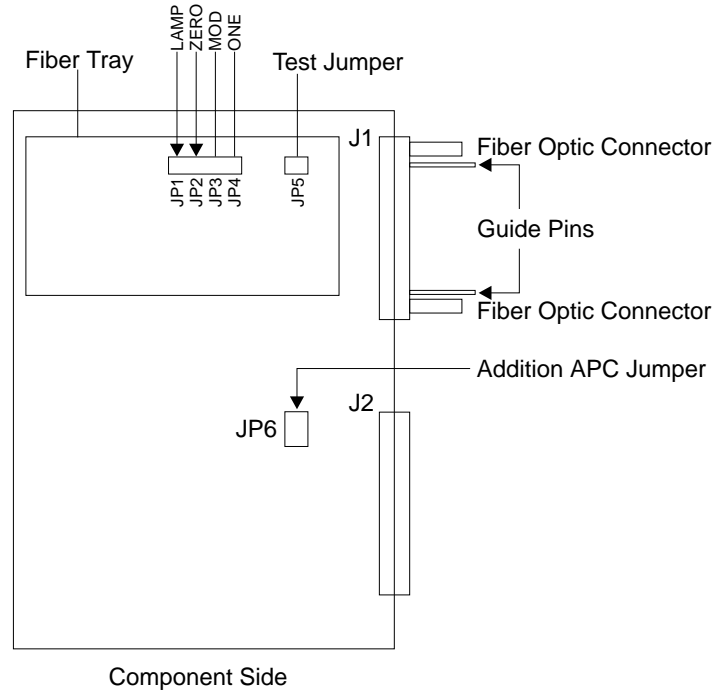

Figure 14. LRC Jumper Locations

- 4 Perform the procedure in “Measuring Received Optical Power and Tuning LRC Wavelength” on page 30.
- 5 Install the replacement card using the procedure in “Removing and Replacing a Generic Card” on page 31.
- 6 Verify that the green Ready LED has turned on and remains on.
- 7 Close the front door of the unit.

Removing and Replacing the Diagnostic Card

You can remove and reinsert the diagnostic card at any time. When you remove the diagnostic card, the green Ready LED may turn OFF on any LRC if the corresponding channel is not active. When you reinsert the diagnostic card, any green Ready LED that turned off should turn on again and remain on. Removal of the diagnostic card does not affect any channels currently in use.

Suspend the SNMP agent that is monitoring the EIA 232 port until this replacement procedure is complete.

Note: The Int LED will blink on and off when the processor on the diagnostic card is running. Pressing the Reset button will restart the diagnostics firmware if the processor has stopped.

- 1** Open the front cabinet door and locate the diagnostic card in slot 11.

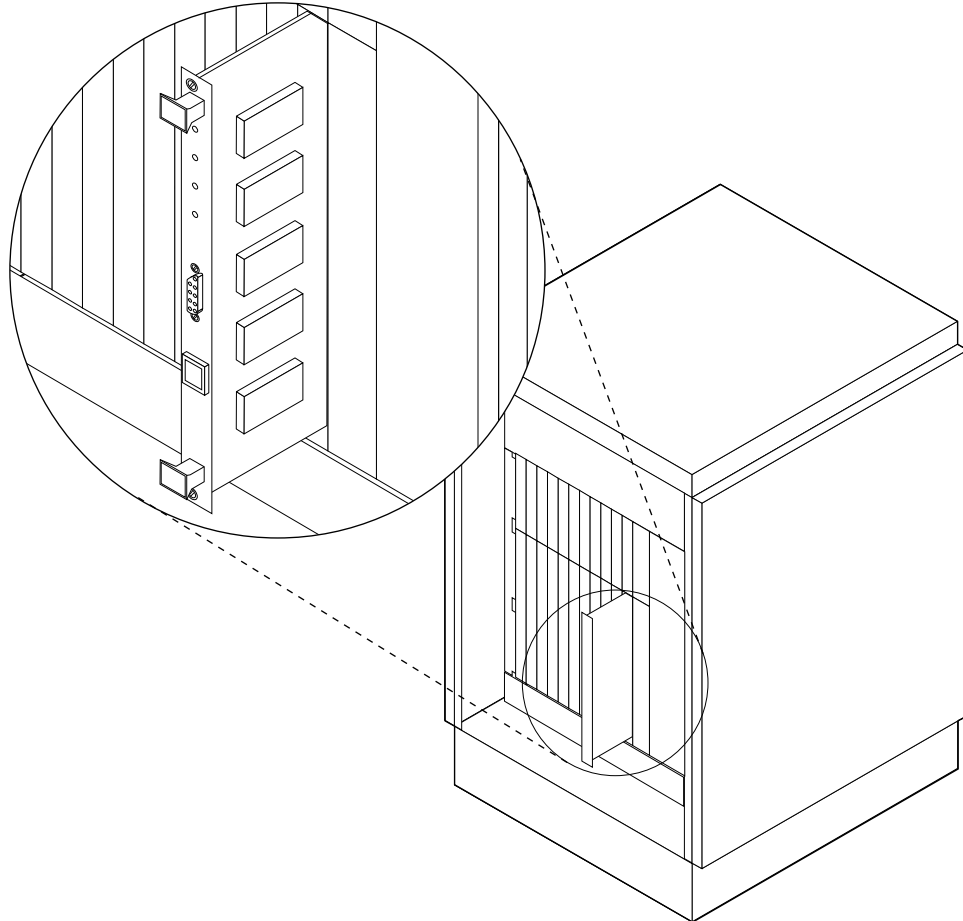
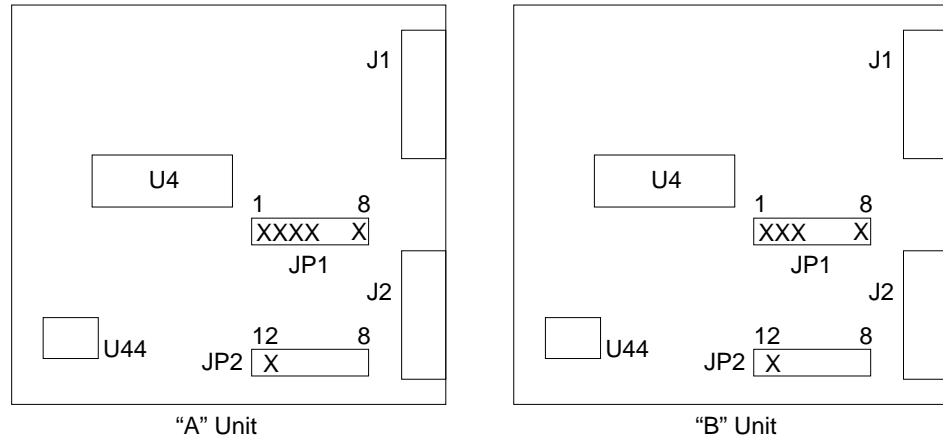

Figure 15. Diagnostic Card Removal and Replacement

- 2** If installed, unplug the cable that is connected to the serial port on the front panel of the diagnostic card.
- 3** Remove the diagnostic card using the procedure in “Removing and Replacing a Generic Card” on page 31.

- 4 Move the jumper blocks from the card you have removed to the card you are installing. Position the jumpers on the new card in the same position as the card you are replacing. See Figure 16 for information on the position of the jumpers.

Diagnostic Card (Component side view) showing U44, U4, JP1, JP2



Note: Recommended setup is Auto mode. Install jumpers shown above (X indicates jumper installed) to configure in Auto Mode

Figure 16. Diagnostic Card Jumpers

Note: The jumper positions and number of jumpers will vary depending on whether the Dual Fiber I/O Card is installed in the machine and whether the machine is an A unit or a B unit.

- 5 Install the replacement card following the procedure in "Removing and Replacing a Generic Card" on page 31.
- 6 Replug the serial port cable if you disconnected it previously. Press the Reset button on the diagnostic card and verify that the Int LED blinks on and off approximately every 2 seconds. Close the front door of the unit.

Removing and Replacing the TEC Card

The Temperature Control (TEC) card can be removed for a short amount of time (less than 10 min.) without causing an increase in the bit error rate. The card can be removed and replaced without affecting the operation of the channels.

The TEC card is located in slot 12.

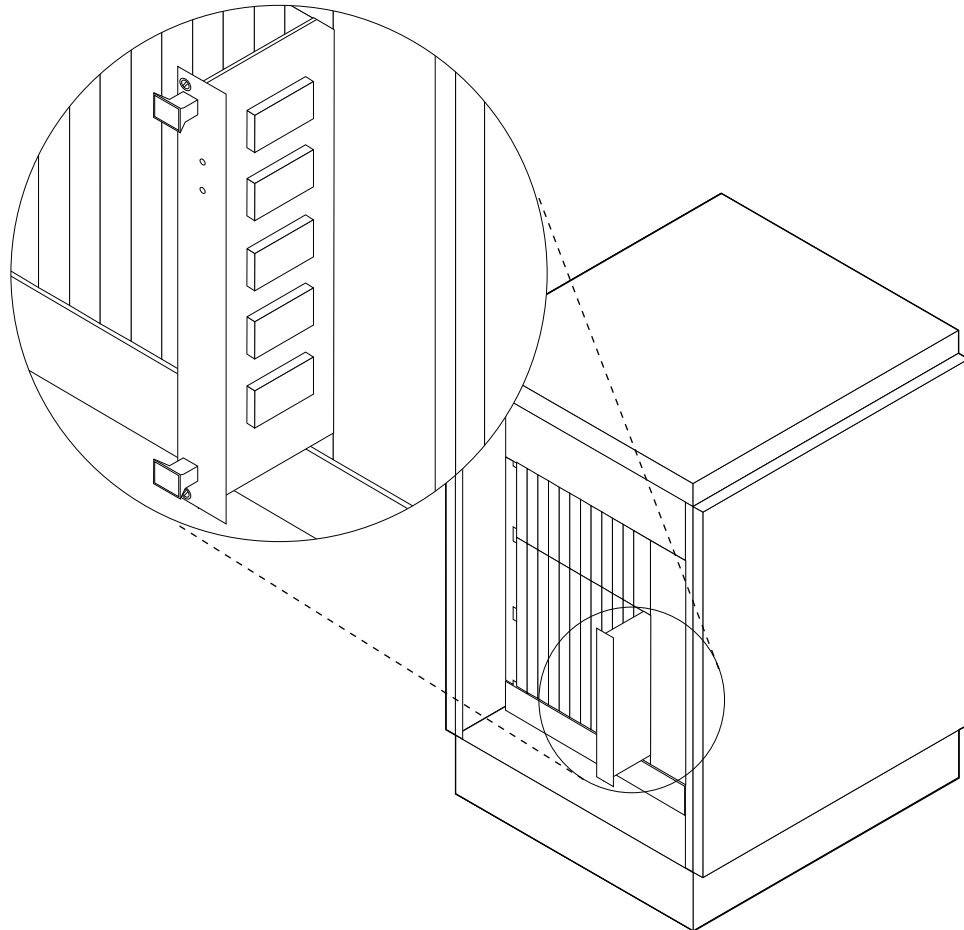

Figure 17. TEC Card Removal and Replacement

- 1** Remove the TEC card using the procedure in “Removing and Replacing a Generic Card” on page 31.
- 2** Install the replacement card using the procedure in “Removing and Replacing a Generic Card” on page 31.
- 3** If you have an old-style TEC card (having 2 LEDs on the front panel), verify that the Green Cool LED lights when a grating cooling cycle is in progress and that the Green Heat LED lights when the grating heating cycle is in progress.

If you have a new-style TEC2 card (having 6 LEDs on the front panel), verify that:

- The green Cool LED lights when a grating cooling cycle is in progress

- The green Heat LED lights when a grating heating cycle is in progress
- All other indicators are off

4 Close the front door of the unit.

Removing and Replacing an IOC

An IOC can be removed or inserted at any time while the unit is powered on without affecting any other channels.

1 Open the front cabinet door and locate the IOC from slots 1 through 10 in the upper section.

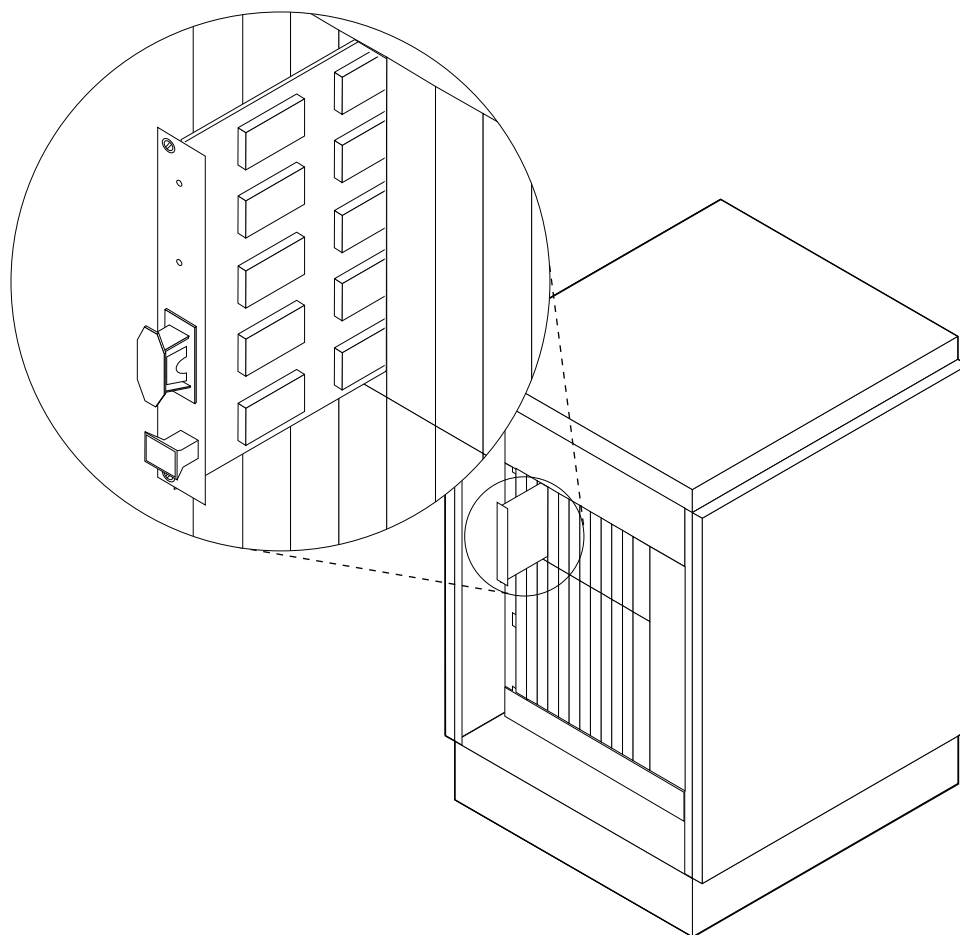

Figure 18. IOC Removal and Replacement

- 2** Unplug the fiber cable from the front of the IOC.
- 3** Remove the IOC using the procedure in “Removing and Replacing a Generic Card” on page 31.
- 4** Install the replacement card using the procedure in “Removing and Replacing a Generic Card” on page 31.

- 5** Clean the fiber connector with an alcohol wipe and plug the fiber cable into the replacement card.
- 6** Close the front door of the unit.

Removing and Replacing the Fiber I/O Card or Dual Fiber I/O Card

Removal of this card will make all channels inoperable.

- 1** Open the front cabinet door and locate the Fiber I/O Card or Dual Fiber I/O Card in slot 12.

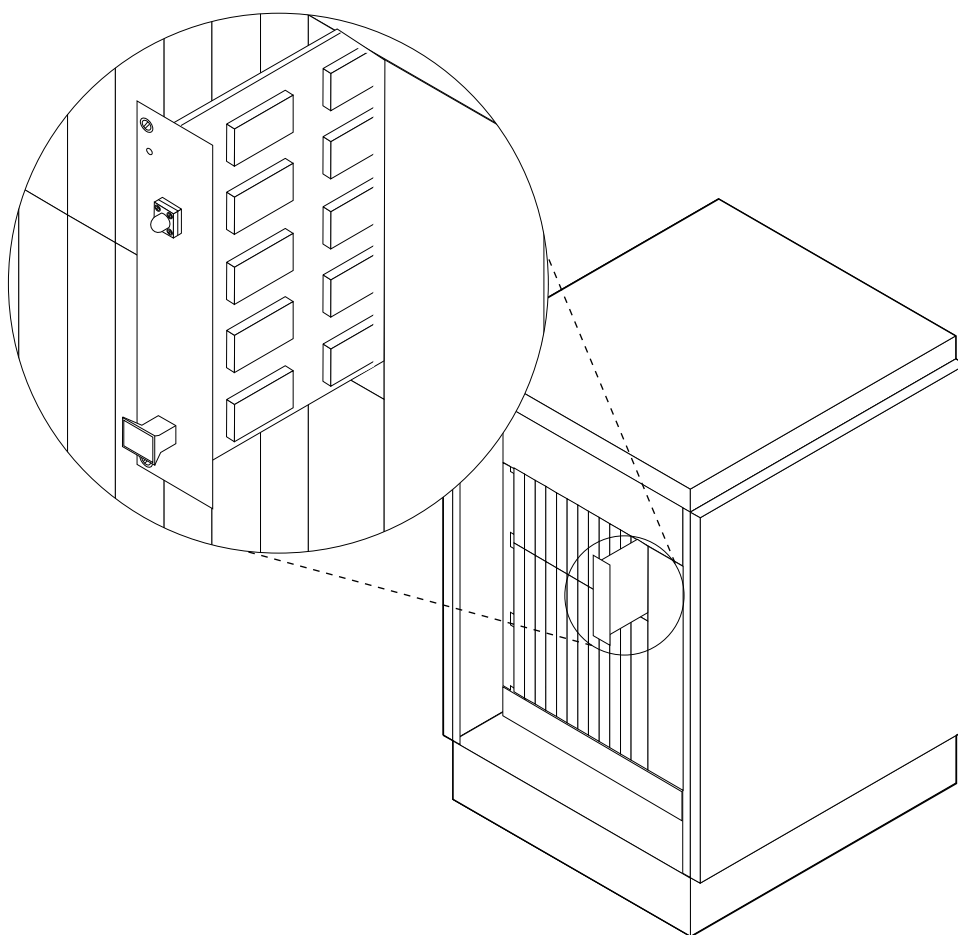

Figure 19. Fiber I/O Card

- 2** Disconnect the front FC/PC fiber connection by turning the collar in a counterclockwise direction until loose, and then pulling it away from the card. Place the fiber-end away from the panel area, taking care not to bend or kink the fiber.
- 3** Remove the card using the procedure in “Removing and Replacing a Generic Card” on page 31.

- 4** Take the replacement card, remove the tip protector from the DIN fiber connector, and clean the connector with alcohol wipes.
- 5** Install the replacement card following the procedure in “Removing and Replacing a Generic Card” on page 31.
- 6** Clean the FC/PC fiber connections with alcohol wipes. Insert, align, and tighten the FC/PC connectors of the single-mode fiber link to the input/output connectors on the card.
- 7** Verify that the green Ready LEDs on all LRCs turn on and remain on.
If the Dual Fiber I/O Card is installed, verify that either the Primary or Secondary LED comes on and remains on.
- 8** Close the front door of the unit.

Removing and Replacing the Grating Assembly

Important: This is a very delicate operation. Fiber optic strands can be damaged very easily. Take extreme care at all times to avoid damage to any fiber optics.

This procedure will make all channels inoperable.

Important: If this unit is a Model 001, it contains a redundant power system; it will have two ac plugs, two power distribution units (PDUs), two ac cables, and so on. If this unit is a Model 041, it may or may not contain a redundant power system. Verify whether or not this 9729 has a redundant power system before continuing with this repair procedure.

- 1** Unlock the rear door of the cabinet using the key. Open the rear door and power off both PDU circuit breakers; if this 9729 does not have a redundant power system, there is only one PDU. Ensure that all power-on indicator lights are off.
- 2** Remove the four power supply connectors (J1 through J4) from the backplane. If this 9729 has no redundant power system, remove only J1 and J2.
- 3** Open the front cabinet door and use the procedure in “Removing and Replacing the Dropdown Panel” on page 55 to remove the dropdown panel from the front of the unit.
- 4** Label all cables and then disconnect them from the IOC slots. Disconnect the front FC/PC fiber connection by turning the collar in a counterclockwise direction until loose and then pulling it away from the fiber I/O card. If a Dual Fiber I/O Card is installed, repeat these steps for the second fiber. Remove the cables from the front cabinet area by routing them to the rear of the cabinet.

- 5** Use the procedure in “Card Cage/Grating Removal, Disassembly, and Reassembly” on page 56 to remove the card cage assembly from the system cabinet.
- 6** Place the removed card cage/grating assembly on a stable surface. Secure it if necessary.
- 7** Disconnect the 6-pin TEC cable connector at the backplane.
- 8** Disconnect the 2-pin fan cable connector at the backplane.
- 9** Loosen the two screws securing the 37-pin temperature sense cable connector to the backplane. Unplug the 37-pin connector from the backplane.
- 10** Carefully unplug all 21 backplane optical (BPO) fiber connectors by applying equal pressure to both sides of the grey connector housing, while pulling the housing away from the backplane. If this is a Model 041, there will be only 9 BPO connectors. Do not put excessive force on the fiber strand during removal. Label each connector as it is removed, for example, “slot 1, top”, along with the fiber label sequence for each slot.
- 11** Remove the four bolts and nuts (two on each side) of the grating mounting bracket. This is the “inverted U” base under the grating box unit, but mounted on top of the card cage unit. Remove the grating assembly from the card cage by tilting the assembly forward so that the tabs on the fiber tray brackets come out of holes 19 and 49 at the top of the card cage easily.
Note: Use a pencil or felt-tip pen to mark holes 19 and 49 for easier identification later.
- 12** Install the new grating assembly by holding it at an angle and inserting the tabs of the fiber tray brackets into holes 19 and 49 on the top of the card cage (count from the left).
- 13** Tilt the new grating assembly into position on the top of the card cage. Align the holes of the mounting bracket with the holes in the card cage, install the four bolts removed previously, and tighten them.
- 14** **Important:** Clean each fiber connector with alcohol wipes before insertion. Avoid physical contact of the optical tip with the metal part of the BPO adapter. The connectors will mate in only one orientation; therefore, rotating the connector 180 degrees may be required. Plug all grating connectors into the BPO adapters in the backplane according to the fiber label sequence recorded on the strands of the removed grating assembly.
- 15** Plug the grating fan into its mating 2-pin connector from the backplane.
- 16** Plug the TEC cable connector into its mating 6-pin connector from the backplane.

- 17** Plug the temperature-sense ribbon cable into its mating 37-pin connector on the backplane and tighten the two retaining screws.
- 18** Use the procedure in “Card Cage/Grating Removal, Disassembly, and Reassembly” on page 56 to reinstall the card cage assembly into the system cabinet.
- 19** Use the procedure in “Removing and Replacing the Dropdown Panel” on page 55 to reinstall the dropdown panel on the front of the unit.
- 20** Reroute the fiber cables that you removed previously to the front IOC area. Clean all fiber connections with alcohol wipes and plug the fiber cables into positions indicated by labels.
- 21** Clean the connectors on the front FC/PC connection and associated fiber with alcohol wipes. Reconnect the fiber to the front FC/PC connection by carefully inserting, aligning, and tightening the connectors.
- 22** Plug the power supply connectors into the backplane connections J1 through J4; if this 9729 has no redundant power system, plug in only the PS1 jumpers. PS1 (top) plugs in to J1 and J2. PS2 (bottom) plugs in to J3 and J4. The connectors are keyed for correct location. **Do not use excessive force.**
- 23** Power on the PDU units at the rear of the system by restoring both PDU circuit breakers. If this 9729 has no redundant power system, there is only one PDU. Ensure that all power-on indicator lights are on.
- 24** Allow the grating temperature to stabilize for 20 minutes.
- 25** Readjust the wavelengths of all the LRCs in both units using the procedure in “Measuring Received Optical Power and Tuning LRC Wavelength” on page 30.
- 26** Verify that the green Ready LED on each LRC turns on and remains on. Close the front door and rear door of the cabinet. Lock the rear door of the cabinet and return the key to its storage place.

Removing and Replacing Optical Adapters

Special Tools: Optical Adapter removal tool, P/N 85H3528

Important: If this unit is a Model 001, it contains a redundant power system; it will have two ac plugs, two power distribution units (PDUs), two ac cables, and so on. If this unit is a Model 041, it may or may not contain a redundant power system. Verify whether or not this 9729 has a redundant power system before continuing with this repair procedure.

DANGER

One of the redundant power systems must be turned off and unplugged during this procedure to ensure your safety. Failure to select the correct power system could result in serious personal injury or the loss of the unit to the customer.

For translations of this safety notice, see Appendix A, “Translated Safety Notices” on page 65.

Important: This is a very delicate operation. Fiber optic strands can be damaged very easily. Take extreme care at all times to avoid damage to any fiber optics.

This procedure requires two service personnel. If this 9729 has a redundant power system, the procedure can be performed without interrupting customer operation.

- 1** Open the front door of the cabinet. Verify that the amber PS 1 FAULT LED and the amber PS 2 FAULT LED on the diagnostic card are both off. If this 9729 does not have a redundant power system, verify only that the PS1 FAULT LED is off. If the 9729 has a fault condition, refer to Chapter 3, “Troubleshooting Procedures” on page 11 to diagnose and repair the problem before proceeding.
- 2** Unlock and open the rear door of the cabinet. Power off the top PDU with its circuit breaker. Ensure that all power-on indicator lights of PDU 1 are OFF. Verify that the amber PS 1 FAULT LED on the Diagnostics Card is ON.
- 3** Remove the card from the slot where the optical adapter must be replaced:
 - If the card is an LRC, use the instructions in “Removing and Replacing an LRC” on page 34
 - If the card is a fiber I/O card, use the instructions in “Removing and Replacing the Fiber I/O Card or Dual Fiber I/O Card” on page 40
- 4** The optical adapter consists of two parts, the metal housing that is accessible from the rear of the backplane and the collar that is located in front of the backplane. While the other service person holds the grey fiber optic connector that is attached to the optical adapter housing, insert the adapter removal tool into the front of the adapter and rotate the tool to align the keys of the tool with the adapter.

If you require more working clearance at the rear of the unit, you can temporarily remove the vertical power-supply bracket and the power supply hanger bracket and reposition the top power supply (PS1) to gain more working clearance.

Important: Do not excessively bend or disturb the optical fibers of adjacent adapters or permanent damage may result.

- 5** While the other service person holds the grey fiber optic connector that is attached to the optical adapter housing, rotate the removal tool counter clockwise until the rear section of the adapter can be pulled away from the

backplane. Remove the connector from the adapter housing and avoid contact with the optical tip.

Note: Identify the key tab on the threaded end of the optical housing to ensure the key tab is positioned correctly when the new adapter housing is inserted.

- 6** Unscrew the front collar from the replacement adapter, clean the optical tip of the connector with alcohol wipes, mate the new adapter housing with the connector, position the key tab to your left, and align the adapter housing with the collar in the backplane. If the original collar is not damaged, you can reuse it on the new adapter. Do not allow the adapter housing in the rear of the backplane to rotate while tightening with the insertion tool. Rotate the insertion tool clockwise until the optical adapter is tight.
- 7** If you repositioned the top power supply (PS1) for more work space, then return the power supply to its original position and reinstall the power-supply hanger bracket and the vertical power-supply bracket using the screws previously removed.
- 8** Reinstall the card that you removed. Verify that the green Ready LEDs on all affected LRCs turn on and remain on.
- 9** Close the front door and rear door of the cabinet. Lock the rear door of the cabinet and return the key to its storage place.

Removing and Replacing a Power Distribution Unit (PDU)

This procedure requires one person. If this 9729 has a redundant power system, the procedure can be performed without interrupting customer operation.

Important: If this unit is a Model 001, it contains a redundant power system; it will have two ac plugs, two power distribution units (PDUs), two ac cables, and so on. If this unit is a Model 041, it may or may not contain a redundant power system. Verify whether or not this 9729 has a redundant power system before continuing with this repair procedure.

DANGER

One of the redundant power systems must be turned off and unplugged during this procedure to ensure your safety. Failure to select the correct power system could result in serious personal injury or the loss of the unit to the customer.

For translations of this safety notice, see Appendix A, “Translated Safety Notices” on page 65.

- 1** Open the front door of the cabinet and verify that the amber PS 1 FAULT LED and the amber PS 2 FAULT LED on the diagnostic card are both off or that if an amber LED is on, it applies to the power system in which the PDU is being replaced. If this 9729 does not have a redundant power system, there is only one PDU.

2 Unlock and open the rear door of the cabinet. Locate the PDU to be replaced and power it off by switching its circuit breaker to the OFF position. PDU1 is located on the top position. PDU2 is located at the bottom position. ***If this 9729 has more than one PDU, power off only the PDU that is to be replaced.*** Ensure that all power-on indicator lights on the PDU being replaced are now OFF. Verify that the appropriate amber PS 1 FAULT LED or PS 2 FAULT LED on the diagnostics card turns on or remains on.

3 Important: Fiber optic strands can be damaged very easily. Take extreme care at all times to avoid damage to any fiber optics.

Remove the cable retaining wraps securing the cord assemblies to the right cabinet wall.

4 Follow the ac line cord of the PDU being replaced to where it can be unplugged from the primary power source. Both ac cords go down along the right side cabinet, under the power supply shelf, and exit the cabinet through the hole at the lower left of the cabinet. If this 9729 has no redundant power system, there is only one ac line cord.

Unplug the ac line cord from its primary power source.

5 Remove the four rail-mounting screws that secure the PDU in position. If you are removing PDU1, the upper unit, this will slide out from a resting position on top of PDU2 as shown in Figure 20.

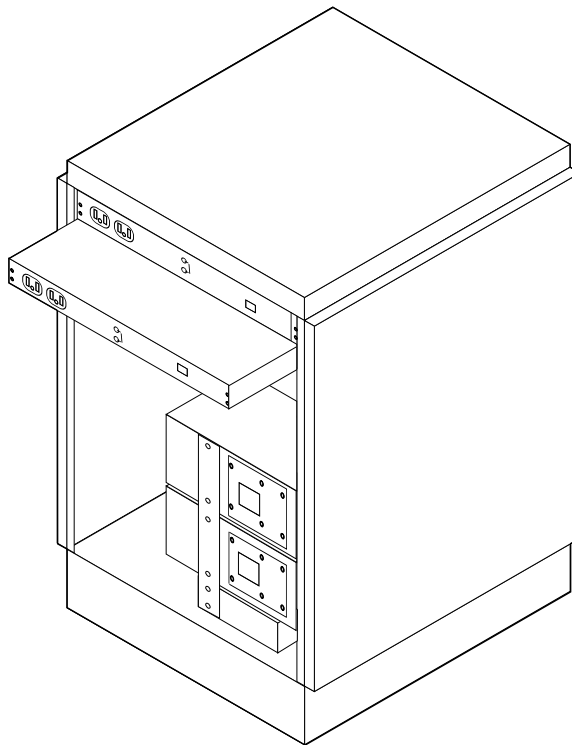

Figure 20. PDU1 Removal

If you are removing PDU2, the lower unit, support it with your hand as you remove the screws.

- 6** Unplug the fan cord from J3 and the power supply cord from J2 located at the rear of the PDU that is being removed.
- 7** **Important: Fiber optic strands can be damaged very easily. Take extreme care at all times to avoid damage to any fiber optic strands.**

Carefully pull the ac line cord up into the cabinet through the hole in the bottom panel and then out from under the power supply shelf. If this 9729 has a redundant power system, the removal of PDU1 requires that the ac line cord be removed through the opening between the top of the cabinet and the top of PDU2.
- 8** If this 9729 has a redundant power system, installation of PDU1 requires the ac line cord be routed through the opening between the top of the cabinet and the top of PDU2. Put the replacement PDU ac cord into position, routing the cord under the power supply shelf and exiting through the hole in the cabinet base.
- 9** Replug the fan cord into J3 and the power supply cord into J2 located at the rear of the PDU that is being installed.
- 10** Put the replacement PDU into position. Secure the PDU with the four rail-mounting screws that you removed previously.
- 11** Redress the ac line cords. PDU cords are tie-wrapped to the cabinet wall, dropping directly down the side and running along the cabinet bottom, and then along the back edge of the fan tray. These two cords must be routed **under** the power supply shelf and exit through the bottom hole in the cabinet.
- 12** Ensure that the circuit breaker on the replacement PDU and its LOCAL/REMOTE switch are both in the OFF position. Plug the ac line cord into its power source.
- 13** Switch the PDU circuit breaker ON and verify that the green light labeled POWER turns on. Set the LOCAL/REMOTE switch to LOCAL. The green light labeled SEQ1 should turn on immediately. After approximately 20 seconds, the green light labeled SEQ2 turns on.
- 14** Verify that the amber PS 1 FAULT LED and the amber PS 2 FAULT LED on the diagnostic card are both OFF.
- 15** Close the front door and rear door of the cabinet. Lock the rear door of the cabinet and return the key to its storage place.

Removing and Replacing a Power Supply

This procedure requires only one person. If this 9729 has a redundant power system, the procedure can be performed without interrupting customer operation.

Important: If this unit is a Model 001, it contains a redundant power system; it will have two ac plugs, two power distribution units (PDUs), two ac cables, and so on. If this unit is a Model 041, it may or may not contain a redundant power system. Verify whether or not this 9729 has a redundant power system before continuing with this repair procedure.

DANGER

One of the redundant power systems must be turned off and unplugged during this procedure to ensure your safety. Failure to select the correct power system could result in serious personal injury or the loss of the unit to the customer.

For translations of this safety notice, see Appendix A, "Translated Safety Notices" on page 65.

- 1** Open the front door of the cabinet and identify the defective power supply by looking at the fault indicators on the front panel of the diagnostic card (slot 11).
- 2** Unlock and open the rear door of the unit. For a PS1 FAULT indication, power off PDU1 (top unit). For a PS2 FAULT indication, power off PDU 2 (bottom unit). If this 9729 does not have a redundant power system, there is only one PDU; power it off.
- 3** Power off the PDU by switching the circuit breaker off and verify that the PDU power indicator lamps are now off and one bank of three fans is stopped.
- 4** Clip the nylon tie wraps holding the power cords to the left cabinet wall. Carefully separate and pull the ac power cord of the power supply away from the other cords.
- 5 Important: Fiber optic strands can be damaged very easily. Take extreme care at all times to avoid damage to any fiber optics.**
Unplug the ac power cord of the defective power supply from the rear of the PDU that is now powered off by reaching under the two PDUs and to the left. The power supply plugs are located on the far end of the PDUs, close to the cabinet wall (left side, viewed from the face of the PDU). Remove power supply 1 plug from PDU1 (top unit). Remove power supply 2 plug from PDU2 (bottom unit). If this 9729 does not have a redundant power system, there is only one power supply plug.
- 6** Unplug the dc power plugs of this power supply from the backplane, at the lower left viewed from the rear access. PS1 power plugs are located at J1 and J2 (the top two dc power plugs). PS2 power plugs are located at J3 and J4 (the bottom two power plugs). If this 9729 has no redundant power

system, you need only unplug power plugs for one power supply; make a note of the locations of these plugs. Remove the two power plugs by squeezing the tabs on both sides of the connector, and remove them. Carefully pull the dc wiring harness away from other cables in the area.

- 7** The power supplies are located at the rear entry of the cabinet and to the lower right, secured in position by metal brackets. PS1 is the top unit and PS2 is the bottom unit. If this 9729 has no redundant power system, there is only one unit.
- 8** Remove the vertical power supply bracket. This is the vertical bracket strapping both power supplies to the power supply shelf at the bottom. Remove all screws from the bracket (two screws from PS1 mounting, two screws from PS2 mounting, and two screws from the shelf mounting).
Note: The shelf-mounting screws are longer than the power supply mounting screws.
- 9** Remove the two screws from the rack mount (right side) of the power supply hanger brackets. If PS1 (top) is being removed, it will slide out with no other operations as shown in Figure 21.

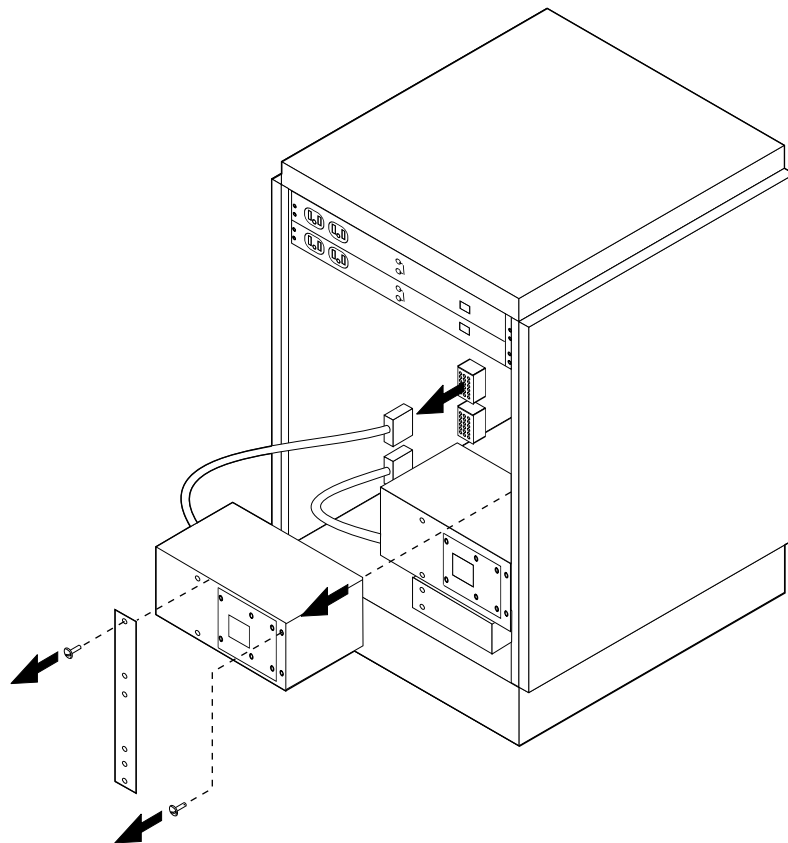

Figure 21. Removing PS1

If PS2 (bottom) is being removed, the two screws in the PS1 bracket may have to be loosened slightly (**do not remove them**) for the lower supply to slide out from under the upper supply.

- 10** Remove the power supply hanger bracket from the defective power supply by removing the four screws.
- 11** Mount the power supply hanger on the replacement power supply assembly using the four screws you removed previously. Tighten securely using a screwdriver.
- 12** Place the replacement power supply assembly with hanger into the empty position with the power cables to the left. Loosely secure the hanger bracket with the two cabinet rail screws you removed previously.
- 13** Install the vertical power-supply bracket you removed previously. Use the four longer screws for the power supplies and the two shorter screws for the shelf. Start these screws but do not tighten. Secure the right side hangers to the cabinet rails using the two rail-mounting screws you removed previously. Now tighten all the bracket and hanger screws.
- 14** Plug the ac power cord into the appropriate PDU: PS1 plugs in to PDU1. PS2 plugs in to PDU2. If this 9729 does not have a redundant power supply, plug the power cord into the only PDU. The plug goes in the first position outlet toward the left innermost part (as viewed from the rear of the unit) of the PDU. Dress the ac cords neatly along the left cabinet wall.
- 15** **Attention:** Do not plug the power supply dc harness into the backplane unless both power systems are powered on. If this 9729 does not have a redundant power system, only one power system must be powered on.

Power on the PDU and verify that both green lights (SEQ1 and SEQ2) are on after approximately 20 seconds.
- 16** Plug the power supply dc cables into the backplane connectors. P1 and P2 of PS1 plug into J1 and J2, and P1 and P2 of PS2 plug into J3 and J4. If this 9729 does not have a redundant power system, plug the power supply dc cables into the locations you noted in step 6 on page 48. These connectors are keyed to avoid misplugging of J1 and J2 or J3 and J4. The orange and blue color-coded wires are for J1 and J3; the red and violet color-coded wires are for J2 and J4.
- 17** A PS FAULT condition will likely occur during plugging of the dc harness and be indicated for this power supply on the front panel of the diagnostic card. Power off the PDU for the power system that indicates the fault and leave the PDU off for 15 to 20 seconds. Power on the PDU and verify that both green lights (SEQ1 and SEQ2) are on after approximately 20 seconds.
- 18** Check the front panel indicators on the diagnostic card to ensure that both PS FAULT LEDs are now off.
- 19** Close the front door and rear door of the cabinet. Lock the rear door of the cabinet and return the key to its storage place.

Removing and Replacing the Backplane

See “Card Cage/Grating Removal, Disassembly, and Reassembly” on page 56 for details.

Removing and Replacing the Fan Tray

Attention: Power must be returned to the fan unit as soon as possible to restore system cooling.

Note: Power does not have to be turned off to replace the fan tray assembly.

- 1** Unlock and open the rear door of the cabinet and locate the two ac fan cords at the bottom left of the fan assembly. The cords use IEC 320 (rectangular) female plugs. Label the plugs left and right so that they will be plugged back to into their correct locations, if you have not already done so.
- 2** Unplug the two ac power cords from the rear of the fan tray.
- 3** Open the front door of the cabinet.

- 4** Using a Phillips screwdriver, remove the fan-tray locking bracket located on the lower left side of the machine, viewed from the front.

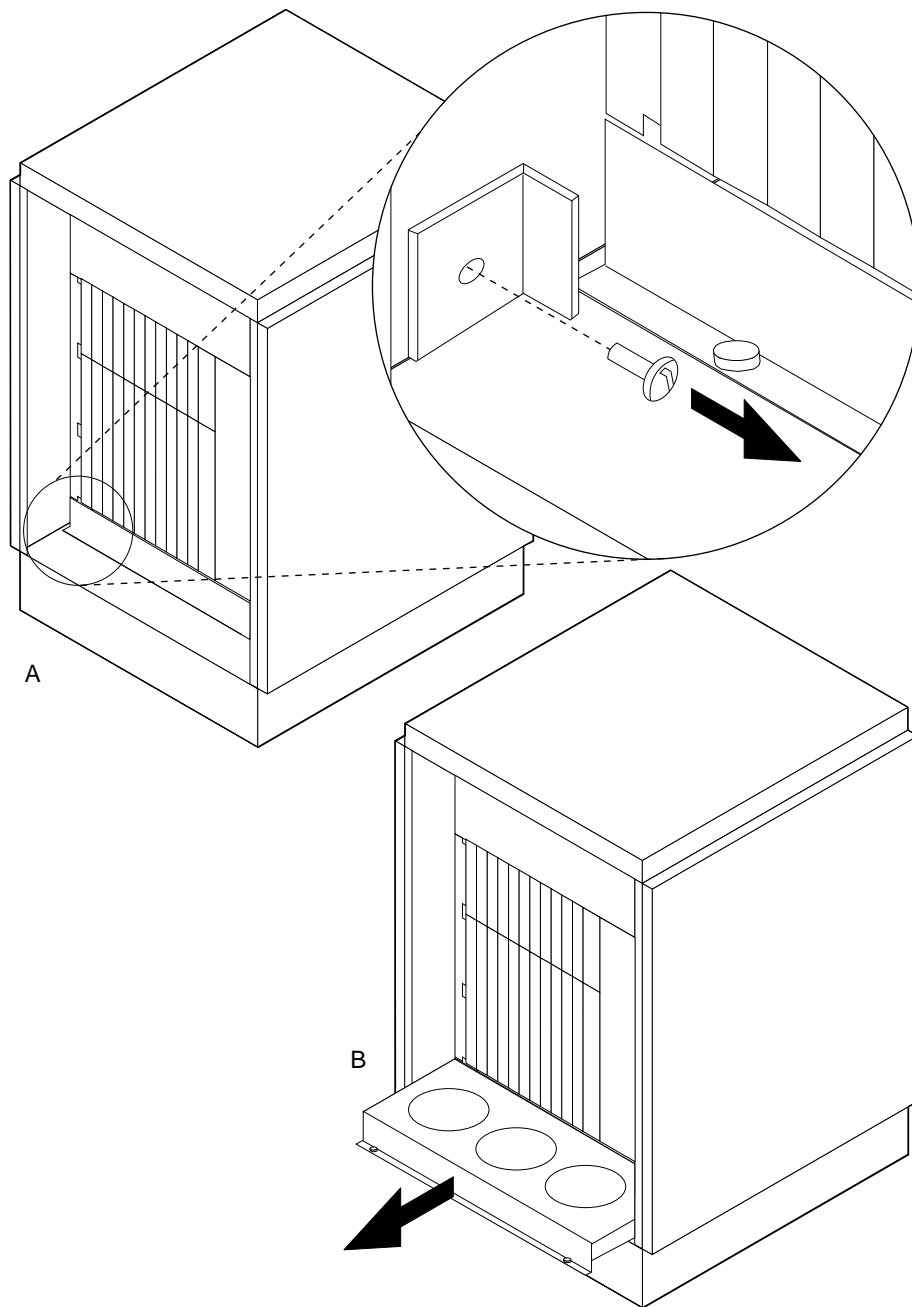

Figure 22. Fan-Tray Locking Bracket and Fan Tray

- 5** The fan tray is located under the card cage and secured by two screwdriver/thumbscrew screws. Use a large flat-blade screwdriver to loosen the screws.
- 6** Slide the fan tray out by pulling it straight forward out and away from the front cabinet access. Keep the door open as wide as possible.

- 7** Check the air filter. Replace if necessary.
- 8** Install the new fan tray assembly. Secure with the two thumbscrews.
- 9** Reinstall the fan-tray locking bracket.
- 10** At the rear, replug the two IEC 320 fan plugs, noting the correct left and right positions.
- 11** Check that all fans are operating and that both PS FAULT LEDs on the diagnostic card are OFF.
- 12** Close the front door and rear door of the cabinet. Lock the rear door of the cabinet and return the key to its storage place.

Removing and Replacing the Fan Filter

Attention: Power must be returned to the fan unit as soon as possible to restore system cooling.

Note: Power does not have to be switched off to replace the fan filter under the fan assembly.

- 1** Remove the fan tray as described in “Removing and Replacing the Fan Tray” on page 51.

-
- 2** Pull the filter out by lifting up and out on the two triangular wire finger grips.

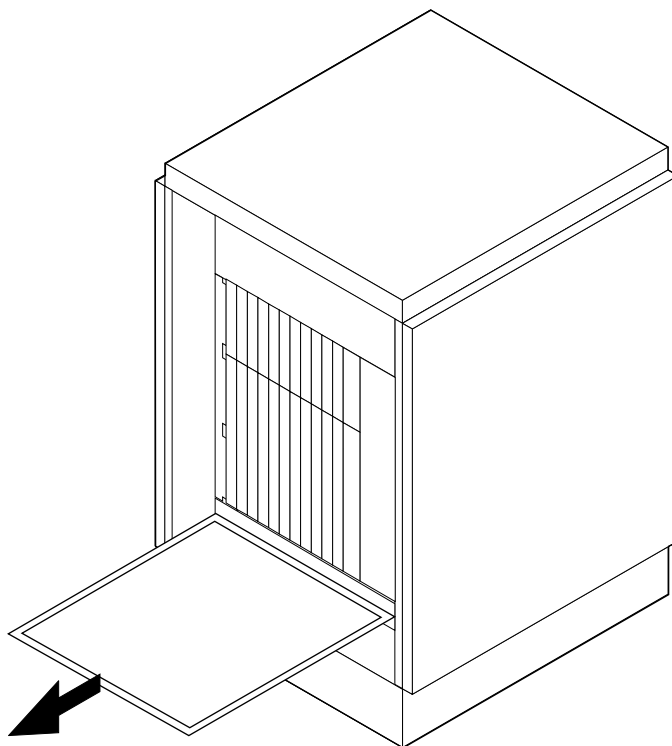

Figure 23. Fan Filter Removal

-
-
- 3** Insert the new filter to its fully rearward position and lower the front of the filter into position.
- 4** Reinstall the fan tray as described in “Removing and Replacing the Fan Tray” on page 51.

Removing and Replacing the Fan Cable

Important: If this unit is a Model 001, it contains a redundant power system; it will have two ac plugs, two power distribution units (PDUs), two ac cables, and so on. If this unit is a Model 041, it may or may not contain a redundant power system. Verify whether or not this 9729 has a redundant power system before continuing with this repair procedure.

The fan cable is used to power a bank of three fans. There is a bank of fans for each power supply. If this 9729 has a redundant power system, there are two fan banks that are plugged into separate PDU assemblies; if this 9729 does not have a redundant power system, there is one bank of fans. It is not necessary to power off the 9729 for this procedure. However, if you want to, you can power off the PDU that powers the fan bank being replaced.

Attention: If this 9729 has a redundant power system, do not power off the second PDU during this procedure.

- 1** Open the rear access door to the cabinet. The fan-tray ac receptacles are located at the lower right inside the unit. The left plug and cable are routed and plugged into PDU1-J3 (top PDU, second rear duplex outlet from the left as viewed from rear access). The right plug and cable are routed and plugged into PDU2-J3 (bottom PDU, second rear duplex outlet from the left as viewed from rear access). If this 9729 does not have a redundant power system, there is only one fan cable.
- 2** Remove the defective fan cable by unplugging it from the PDU and then from the fan tray as described in step 1. Clip any cable retainer wraps securing the ac cables to the cabinet wall.
- 3** Install the new ac fan cable. Plug the IEC 320 end into the fan tray and the other end into the PDU.
- 4** Redress and secure the ac cables.
- 5** Check that all fans are operating.
- 6** Close the rear door of the cabinet. Lock the rear door of the cabinet using the key. Return the key to its storage place.

Removing and Replacing the Dropdown Panel

The dropdown panel is located at the front access of the unit, upper section above the plug-in circuit cards and card cage area.

- 1** Open the front door of the cabinet.
- 2** Remove the two rack-rail mounting screws from the panel, one on each side. The panel will drop forward and down, being hinged at the bottom.
- 3** Carefully remove all fiber cables from the cable restraining clips located on the inside of the panel. The cables will then be loose, but still hanging over the panel. The cables will still be plugged into their associated IOC location.
- 4** Remove the two screws securing the hinge of the dropdown panel to the rail. The panel assembly will drop free, but will have to be carefully guided around any fiber cables so as not to damage any fibers.
- 5** Mount the new dropdown panel assembly above the card cage assembly. Carefully guide the panel assembly through the fiber cables. Secure the hinge section first to the side rails using the two countersink flathead screws that you removed previously.
- 6** Reposition the fiber cables in the cable retaining clips.
- 7** Close the panel (put it in the up position) and secure it with the two rack-rail mounting screws removed in step 2.
- 8** Close the front door of the cabinet.

Card Cage/Grating Removal, Disassembly, and Reassembly

Important: This is a very delicate operation. Fiber optic strands can be damaged very easily. Take extreme care at all times to avoid damage to any fiber optics.

This procedure will make the 9729 inoperable.

Important: If this unit is a Model 001, it contains a redundant power system; it will have two ac plugs, two power distribution units (PDUs), two ac cables, and so on. If this unit is a Model 041, it may or may not contain a redundant power system. Verify whether or not this 9729 has a redundant power system before continuing with this repair procedure.

Unlock the rear door of the cabinet using the key. Open the rear door and power off both PDU circuit breakers. Ensure that all the power-on indicator lights are OFF.

Removing the Card Cage Assembly

- 1** Remove the power supply connectors from the backplane. If this 9729 has a redundant power system, remove jumpers J1 through J4. If the 9729 does not have a redundant power system, unplug the two power supply connectors and note their locations.
- 2** Use the procedure in “Removing and Replacing the Dropdown Panel” on page 55 to remove the dropdown panel from the front of the unit.
- 3** Label all IOC cables, and then disconnect them from the IOC slots. Remove the cables from the front cabinet area by routing them to the rear of the cabinet.
- 4** If more than one single-mode I/O fiber is present, label all the single-mode I/O fibers. Disconnect the front FC/PC fiber connection by turning the collar in a counterclockwise direction until loose and then pulling it away from the Fiber I/O Card or Dual Fiber I/O Card. Place the fiber end away from panel area, taking care not to bend or kink the fiber.
- 5** Remove the card cage assembly from the front entry of the system cabinet by first removing the 12 rail-mounting screws (6 from each side at the front of the card cage). Gently pull the card cage assembly out, tilting the top of the unit slightly inward for clearance with the grating heatsink and the cabinet top.
- 6** Place the removed card cage/grating assembly on a stable surface. Secure it if necessary.

Disassembling the Card Cage Assembly

To disassemble the card cage assembly, use the following procedures to separate it into:

- The grating assembly
- The backplane
- The card cage

Removing the Grating Assembly

- 1** Disconnect the 6-pin TEC cable connector at the backplane.
- 2** Disconnect the 2-pin fan cable connector at the backplane.
- 3** Loosen the two screws securing the 37-pin temperature-sense cable connector to the backplane. Unplug the 37-pin connector from the backplane.
- 4** Carefully unplug all 21 backplane optical (BPO) fiber connectors by applying equal pressure to both sides of the grey connector housing, while pulling the housing away from the backplane. If this is a Model 041, there will be only 9 BPO connectors. Do not put excessive force on the fiber strand during removal. Label each as they are removed, for example, “slot 1, top”, along with the fiber label sequence for each slot.
- 5** Remove the four bolts and nuts (two on each side) of the grating mounting bracket. This is the “inverted U” base under the grating box unit, but mounted on top of the card cage unit. Remove the grating assembly from the card cage by tilting the assembly forward so that the tabs on the fiber tray brackets come out of holes 19 and 49 at the top of the card cage easily.

Removing the Backplane

- 1** Remove all IOCs, LRCs, the diagnostic card and the TEC card from the card cage. Use these removal procedures:
 - “Removing and Replacing an IOC” on page 39
 - “Removing and Replacing an LRC” on page 34
 - “Removing and Replacing the Diagnostic Card” on page 35
 - “Removing and Replacing the TEC Card” on page 38

Place the cards in a secure area and avoid damage to any optical connectors during handling.

- 2** Remove the backplane ground strap from the card cage. This is secured by a cage-assembly allen screw on the right side of the cage (front view of cage).
- 3** Place the card cage and backplane assembly on a work area face down (rear facing upward and top furthest away). Remove the mounted backplane assembly from the card cage by removing the 34 screws and 4 backplane spacer strips mounted between the backplane and the card cage frame.

Note: Screws are used only on the rows with the spacer strips under the backplane and are placed in every other screw hole.

- 4** Carefully remove the backplane assembly from the card cage position.
- 5** Remove the backplane spacer strips, noting the positioning of the index tabs on top of the inserted threaded insert strips at horizontal rows 1, 2, 5, and 6.

The grating assembly, backplane assembly, and card cage are now separated.

Reassembling the Card Cage Assembly

To reassemble the card cage assembly, mount the backplane and grating assembly on the card cage using the following procedures.

Mounting the Backplane on the Card Cage

- 1** Place the assembled card cage on a work area face down (rear facing upward and top furthest away).
- 2** Place the backplane spacer strips, index tabs down, on top of the previously inserted threaded insert strips at horizontal rows 1, 2, 5, and 6. (Check these locations of the threaded inserts and correct them if necessary.)
- 3** Carefully place the backplane assembly into position, (circuit board DIN connectors facing down or into the card cage, corner cutout of backplane toward the left top of card cage) aligning the screw holes with the holes in the backplane spacer strips.
- 4** Mount the backplane into position with the previously removed 34 screws, skipping every other screw hole. Use screws only in rows with the spacer strips under the backplane. ***Do not tighten yet.***
- 5** Reposition the card cage to its normal upright position. Place an IOC in IOC slot #1 and check for minimum sideways movement of the connector. Realign the backplane if necessary. Repeat for IOC slot #10 and LRC slot #10, even if slots 10 were originally empty.
- 6** After correct alignment of the backplane, tighten all backplane screws.
- 7** Attach the backplane ground lug to one of the allen-head card cage mounting screws on the right side (front facing view).
- 8** Clean each fiber connector and carefully insert all LRCs previously removed. If an LRC was not originally located in slot #10, insert it in its original slot now.
- 9** Reinstall all IOCs previously removed. If an IOC was not originally located in slot #10, insert it in its original slot now.

Mounting the Grating Assembly

- 1** Install the new grating assembly by holding it at an angle and inserting the tabs of the fiber tray brackets into holes 19 and 49 on the top of the card cage (count from the left).
- 2** Tilt the new grating assembly into position on the top of the card cage. Align the holes of the mounting bracket with the holes in the card cage and insert the four bolts removed previously. Install the four nuts removed previously and tighten.
- 3** *Important:* Clean each fiber connector with alcohol wipes before insertion. Avoid physical contact of the optical tip with the metal part of the BPO adapter. The connectors will mate only in one orientation, so you may need to rotate the connector 180 degrees. Plug all grating connectors into the optical adapters in the backplane according to the fiber label sequence recorded on the strands of the removed grating assembly.
- 4** Plug the grating fan into its mating 2-pin connector from the backplane.
- 5** Plug the TEC cable connector into its mating 6-pin connector from the backplane.
- 6** Plug the temperature-sense ribbon cable into its mating 37-pin connector on the backplane and tighten the two retaining screws.

Installing the Card Cage Assembly

- 1** Reinstall the card cage/grating assembly in the system cabinet. Gently insert the card cage assembly into the front of the unit, while tilting the top of the unit slightly inward to gain clearance between the heatsink and cabinet top. Mount the card cage into position using the 12 rail-mounting screws that you removed previously.
- 2** See “Removing and Replacing the Dropdown Panel” on page 55 to reinstall the Dropdown panel on the front of the unit.
- 3** Reroute the fiber and IOC cables to the front IOC area as removed previously. Clean all fiber connections with alcohol wipes and plug the fiber IOC cables into positions indicated by labels. Insert, align, and tighten the FC/PC connector of the single-mode fiber link to the input/output interconnect on the Fiber S/T card.
- 4** Plug the power supply connectors into the backplane connections. If this 9729 has a redundant power system, plug in J1 through J4; PS1 (top) plugs in to J1 and J2, and PS2 (bottom) plugs in to J3 and J4. If this 9729 does not have a redundant power system, plug in only J1 and J2. The connectors are keyed for correct location. **Do not use excessive force.**
- 5** Power on the PDUs at the rear of the system by restoring both PDU circuit breakers. If this 9729 does not have a redundant power system, power on only one PDU. Ensure that all power-on indicator lights are ON.

- 6** Allow the grating temperature to stabilize for 15 minutes.
- 7** **Note:** Omit this step if you did *not* replace the grating assembly.
Readjust the wavelengths of all the LRCs in both units using the procedure in “Measuring Received Optical Power and Tuning LRC Wavelength” on page 30.
- 8** Verify that the green Ready LEDs on all LRCs turn ON and remain ON.
- 9** Close the front door and rear door of the cabinet. Lock the rear door of the cabinet and return the key to its storage place.

Replacing the Grating Fan

Note: This procedure will make the 9729 inoperable.

Important: This is a very delicate operation. Fiber optic strands can be damaged very easily. Take extreme care at all times to avoid damage to any fiber optics.

- 1** Remove the card cage from the unit (see “Card Cage/Grating Removal, Disassembly, and Reassembly” on page 56 for details). After placing the card cage assembly securely on a work area, continue with the next step.
- 2** Disconnect the 2-pin grating fan connector from the backplane cable. Remove any cable-retaining tie wraps if necessary.
- 3** Remove the two fan-housing mounting screws located under the grating fan. Take care when working around the optical fiber cables and strands. Remove the fan and housing assembly.
- 4** Install the replacement grating fan with fan-housing assembly using the two mounting screws that you previously removed.
- 5** Connect the 2-pin grating fan connector to its mating backplane connector.
- 6** Redress the cables neatly and secure them with cable ties if necessary.
- 7** Reinstall the card cage in the unit. See “Card Cage/Grating Removal, Disassembly, and Reassembly” on page 56 for details.
- 8** Verify that the green Ready LEDs on all LRCs turn ON and remain ON. Close the front door and rear door of the cabinet. Lock the rear door of the cabinet and return the key to its storage place.

Replacing Coaxial Cable

Special Tools: Coaxial cable removal tool - P/N 85H3527

Important: If this unit is a Model 001, it contains a redundant power system; it will have two ac plugs, two power distribution units (PDUs), two ac cables, and so on. If this unit is a Model 041, it may or may not contain a redundant power system. Verify whether or not this 9729 has a redundant power system before continuing with this repair procedure.

DANGER

This procedure should be done with both of the redundant power systems turned off to ensure your safety and to prevent an unscheduled loss of the unit to the customer.

For translations of this safety notice, see Appendix A, "Translated Safety Notices" on page 65.

Notes:

1. This procedure will make the 9729 inoperable.
2. This procedure requires only one service person.

1 Unlock the rear door of the cabinet. Open the rear door and power off the top and bottom PDU by switching the circuit breakers to their OFF position. If this 9729 does not have a redundant power system, there is only one PDU.

2 Verify that all the front panel LEDs are now OFF.

3 Remove the IOC and the LRC from the slot where the coaxial cable is to be replaced; use the instructions in "Removing and Replacing an IOC" on page 39 and "Removing and Replacing an LRC" on page 34. Exercise caution when handling the LRCs to avoid damage to the optical contacts.

4 Each connector housing has four holes at the top and four holes at the bottom. These will be referenced as 1 through 8 starting at the top. One pair of coaxial cables, holes 3 and 4 of each connector housing, are used to connect the LRC receive circuit to the IOC transmit circuit. The other pair of coaxial cables, holes 5 and 6 of each connector housing, connect the IOC receiver circuit to the LRC laser circuitry.

From the rear of the unit, identify the coaxial cable to be replaced and tape it to the adjacent coaxial cable so it will not drop down into the base after being extracted from the connector housing.

5 Important: Fiber optic strands can be damaged very easily. Take extreme care at all times to avoid damage to any fiber optics.

From the front of the unit, guide the coaxial removal tool into the IOC connector position that holds the coaxial cable being removed. Avoid contacting the tool with the adjacent cards (if present). Rotate the tool to align the slots with the keys in the connector and slide the tool into the connector until seated.

- 6** While holding the main body of the tool firmly in place, push on the plunger portion of the tool to extract the coaxial cable from the connector housing.
- 7** From the front of the unit, guide the coaxial removal tool into the LRC connector position that holds the other end of the coaxial cable being removed. Avoid contacting the tool with the adjacent cards (if present). Rotate the tool to align the slots with the keys in the connector and slide the tool into the connector until seated.
- 8** While holding the main body of the tool firmly in place, push on the plunger portion of the tool to extract the coaxial cable from the connector housing.
- 9** From the rear of the unit, free the coaxial cable ends from the connector housing and remove the coaxial cable and the tape from the unit.
- 10** Install the new coaxial cable ends into their respective connector housings and push firmly until fully seated. Usually an audible click can be heard upon seating the cable. The coaxial cable should not come out of the connector housing when pulled from the rear.
- 11** Reinstall the IOC, clean the fiber connectors with alcohol wipes, and reinstall the LRC that you previously removed.
- 12** Restore power to the unit. If this 9729 has a redundant power system, switch both circuit breakers to the ON position; if this 9729 does not have a redundant power system, switch on the one circuit breaker. Verify the green *Ready* LEDs on all LRCs turn ON and remain ON. Verify both PS FAULT indicators are OFF.
- 13** Close the front door and rear door of the cabinet. Lock the rear door of the cabinet and return the key and the coaxial removal tool to their respective storage places.

Testing the Operation of Open-Fiber Detection Circuitry

- 1** If the 9729 can be shut down:
 - a** Disconnect the link fiber from the 9729 output.
 - b** Connect an optical power meter set to 1550 nm to the output of the 9729 using a single-mode FC/PC to FC/PC fiber. The measured power level must be 900 microwatts or less.
 - c** Reconnect the link fiber.
- 2** To test a single channel after servicing an LRC:
 - a** Before removing the LRC from the extender, connect an optical power meter set to 1550 nm to the laser output connector on the extender card.

- b** Temporarily remove the diagnostic card from the cage by unscrewing the top and bottom panel screws and pressing the ejectors until the card has been unplugged from the backplane.
- c** Disconnect the fiber connecting RI to RO on the extender card.
- d** Check that the power reading is less than 1 microwatt.
- e** Reconnect the fiber connecting RI to RO.
- f** Remove the LRC from the extender card and reinstall it in the 9729.
- g** Reinstall the diagnostic card by pushing firmly on the front panel just above the lower ejector and at the top of the front panel, and then tighten the top and bottom locking screws.

Appendix A. Translated Safety Notices

This appendix contains safety information for this book.

9729 ISC Card Laser Safety Compliance Requirements

The 9729 ISC card is designed and certified as a Class 1 laser product. It is to be used only with another IBM-produced ISC device or a certified equivalent in a point-to-point configuration. The equivalent must contain the Open Fiber Control system as described in the Fiber Channel standard. This is a requirement for correct operation of the ISC card.

CAUTION:

Connection of an ISC card to a non-approved optical source, or otherwise operating the ISC card in a manner inconsistent with its design and function may result in hazardous radiation exposure, and may be considered an act of modifying or new manufacturing of a laser product under US regulations contained in 21 CFR(J) or requirements contained in IEC 825-1 or EN 60825-1.

The person performing such an act is required by law to recertify and reidentify the product in accordance with the provisions of 21 CFR(J) for distribution in the USA, and in countries subject to the requirements of IEC 825-1 or EN 60825-1 are responsible for compliance with those requirements.

Safety

The 9729 is a CLASS 1 LASER PRODUCT and is certified to comply with IEC 825-1:1993 / EN 60825-1:1994 and 21 CFR subchapter J of DHHS.

The laser's average output level is held constant by an automatic power control circuit. The average power output of the laser is 900 microwatts, under normal operating conditions, at time of manufacture. The laser is modulated with a dc balanced signal at a maximum data rate of 1.0625 gigabits per second. The automatic power control circuit operates in the absence of a signal.

If the automatic power control system fails, the system will still remain Class 1.

The laser wavelengths in the system are between 1539.5 nanometers (nm) and 1559.5 nm at the time of manufacture. The wavelengths will remain between 1539 nm and 1560 nm after manufacture.

CAUTION:

In order to minimize laser exposure, do not press more than one "Test Laser" button at a time or have more than one Test jumper installed at a time. Remove all Test jumpers after measurements and troubleshooting are complete.

For translations of this safety notice, see "Caution Notice" on page 75.

The average power of the laser can increase or decrease by 100 microwatts after manufacture. The system contains an Open Fiber Detection Circuit to limit laser exposure in the event of an open fiber at the output of the system. The time delay

before limiting occurs is 1 second maximum. Pressing the Test Laser button on the Laser/Receiver Card defeats the Open Fiber Detection Circuit for that card, for the purpose of measurements and troubleshooting. Installing the jumper labelled "Test" on the Laser/Receiver Card also defeats the Open Fiber Detection Circuitry. It is expected that there will be a measurement uncertainty in the test equipment of +0/-50% due to connector insertion loss.

Danger Notices



Danger: This unit has more than one power cord. To reduce the risk of electrical shock, disconnect both power supply cords prior to servicing.



GEVAAR:
Bij deze eenheid hoort meer dan één netsnoer. Om gevaar van elektrische schokken te vermijden, moet u beide netsnoeren loskoppelen alvorens onderhoudstaken uit te voeren.



PERIGO:
Esta unidade possui mais de um cabo de alimentação. Para reduzir o risco de choque elétrico, desconecte ambos os cabos da fonte de alimentação antes de efetuar a manutenção.



FARE!
Enheden har flere netledninger. Undgå elektrisk stød: Afmonter begge netledninger, før enheden efterses.



VAARA:
Tässä yksikössä on useita verkkojohtoja. Irrota ne kaikki, ennen kuin aloitat huoltotoimet. Muutoin voit saada sähköiskun.



DANGER:
Cette unité possède deux cordons d'alimentation. Pour limiter les risques électriques déconnectez les deux cordons avant d'intervenir.



VORSICHT:
Diese Einheit verfügt über mehr als ein Netzkabel. Um die Gefahr eines elektrischen Schlages zu vermeiden, vor der Durchführung von Wartungsarbeiten beide Netzkabel aus der Netzsteckdose ziehen.



VIGYÁZAT! VESZÉLY!

Ennek az egységnek egynél több hálózati csatlakozókábele van. Az elektromos áramütés kockázatának csökkentése érdekében, húzza ki az összes hálózati csatlakozókábelt a fali aljzatból a szervizelés megkezdése előtt!

**PERICOLO:**

Questa unità ha più di un cavo di alimentazione. Per ridurre il rischio di scosse elettriche, scollegare entrambi i cavi di alimentazione prima di effettuare l'assistenza.



危険:

この装置には複数の電源コードがあります。感電の恐れがありますので、すべての電源コードを取り外してから保守を行ってください。

**위험:**

이 장치는 전원 코드가 여러 개입니다. 감전의 위험을 줄이려면, 작업하기 전에 전원 코드들을 뽑으십시오.

**FARE:**

Denne enheten har mer enn en nettkabel. For å redusere faren for elektrisk støt kobler du fra begge nettkablene før det utføres service.

**NIEBEZPIECZEŃSTWO:**

Ta jednostka posiada więcej niż jeden kabel zasilający. Aby uniknąć ryzyka porażenia elektrycznego, należy odłączyć oba przewody zasilające przed przystąpieniem do obsługi serwisowej.

**PERIGO:**

Esta unidade tem mais do que um cabo de alimentação. Para reduzir o risco de choques eléctricos, desligue ambos os cabos de alimentação, antes de executar qualquer serviço de manutenção ou assistência.



ОПАСНО:

Это устройство снабжено несколькими кабелями питания. Перед обслуживанием для предотвращения поражения электрическим током отсоедините все кабели питания.



PELIGRO: Esta unidad tiene más de un cable de alimentación. Para reducir el riesgo de descarga eléctrica, desconecte ambos cables de alimentación antes de proceder a cualquier reparación.



危險：

本裝置有一條以上的電源線。爲了避免受到電擊，
維修之前，請先拔掉所有電源線。



Danger: This procedure should be done with both of the redundant power systems turned off to ensure your safety and to prevent an unscheduled loss of the unit to the customer.



Gevaar: Deze procedure moet worden uitgevoerd terwijl beide redundante voedingsbronnen zijn uitgeschakeld, om uw veiligheid te verzekeren en om een onvoorzien verlies van de eenheid voor de klant te voorkomen.



Perigo:

Este procedimento deve ser executado com ambos os sistemas redundantes de alimentação desligados para garantir sua segurança e para evitar uma perda não programada da unidade para o cliente.



危险: 为确保您的安全，避免客户计划外的元件损毁，此过程必须在关闭所有的供电系统的条件下进行。



- Da bi minimizirali uticaj laserskog zracenja ne pritiskati vise od jednog dugmeta istovremeno niti spajati vise od jednog test prespojnika istovremeno. Odspojiti sve koriætene test prespojnik e nakon sto su mjerenja i popravci izvršeni.



Aby byla zajištěna Vaše bezpečnost a nedošlo k nechtěnému poškození jednotky, provádějte tuto proceduru při vypnutí obou náhradních napájecích systémů.



Fare: Denne procedure skal udføres med begge sikkerhedsstrømsystemer slukket for at undgå stød og beskadigelse af kundens enhed.



Fare: Denne prosedyren må utføres mens begge de ekstra strømforsyningssystemene er slått AV så du ikke utsettes for fare og for å unngå at kundens enhet går tapt.



Vaara: Tämän toiminnon ajaksi molemmista jännitelähteistä on katkaistava virta turvallisuuden takaamiseksi ja laitteen vioittumisen estämiseksi.



Danger Cette procédure doit être mise en oeuvre alors que les deux systèmes d'alimentation redondante sont éteints afin de préserver votre sécurité et d'éviter au client la perte imprévue de l'unité pour le client.



Vorsicht: Dieser Vorgang sollte aus Sicherheitsgründen nur durchgeführt werden, wenn beide redundanten Stromversorgungssysteme ausgeschaltet sind, um einen Verlust der Einheit zu verhindern.



VIGYÁZAT, VESZÉLY!

Ezt az eljárást mindkét kikapcsolt tartalékolt tápellátó rendszernél végre kell hajtani az Ön biztonsága és az egészség váratlan kiesésének elkerülése érdekében!



Pericolo: Per sicurezza e per impedire la perdita non preventivata dell'unità per il cliente, questa procedura deve essere eseguita con entrambi i sistemi di alimentazione di scorta scollegati.



危険: 安全のため、またお客様の装置に予期しない損傷を与えないために、この手順を実行する場合は、両方のパワー・システムの電源を切って、行なう必要があります。



위험

사용자의 안전을 보장받고 고객에게 예상치 않은 장비의 손상을 방지하려면, 여분의 전원 시스템 모두를 끄고 이 절차를 완료해야 합니다.



Fare: Denne prosedyren må utføres mens begge de ekstra strømforsyningsystemene er slått AV så du ikke utsettes for fare og for å unngå at kundens enhet går tapt.



Niebezpieczeństwo: Dla bezpieczeństwa osobistego oraz ochrony przed uszkodzeniem urządzenia, procedurę tę należy wykonywać po wyłączeniu obu nadmiarowych systemów zasilania.



Perigo: Este procedimento deve ser executado com ambos os sistemas de alimentação de reserva desligados, para segurança do utilizador e para evitar uma inesperada impossibilidade de utilização da unidade por parte do cliente.



Опасно:
В целях безопасности эту процедуру следует выполнять, предварительно отключив оба резервных блока питания, иначе заказчик может преждевременно лишиться своего устройства.



Peligro: Este procedimiento debe hacerse con ambos sistemas de alimentación redundante apagados para cuidar de su seguridad y evitar una pérdida no planificada de la unidad del cliente.



Fara: Den här proceduren ska utföras med båda de redundanta kraftsystemen avstängda. I annat fall kan allvarliga person- och/eller maskinsador uppstå.



Danger: One of the redundant power systems must be turned off and unplugged during this procedure to ensure your safety. Failure to select the correct power system could result in serious personal injury or the loss of the unit to the customer.



Gevaar: Om uw veiligheid tijdens deze procedure te waarborgen moet één van de redundante voedingsbronnen worden afgezet en worden afgekoppeld van de stroomtoevoer. Indien een verkeerde voedingsbron wordt geselecteerd, kan dit ernstige persoonlijke letsels tot gevolg hebben of kan de eenheid voor de klant verloren gaan.



Perigo:

Um dos sistemas redundantes de alimentação deve ser desativado e desligado durante este procedimento para garantir sua segurança. Falha ao selecionar o sistema de alimentação correto poderia resultar em sérios danos pessoais ou perda da unidade para o cliente.



危险: 为保证您的安全，在此过程中，请将多余的供电系统关闭并拔下电源插头。没有成功地选择正确的供电系统将造成严重的个人伤害或损毁客户的元件。



- Redundanti izvor napajanja mora biti isključen i odspojen za vrijeme ovog postupka zbog vaše sigurnosti. Pogresan odabir naponskog izvora može dovesti do ozbiljnih oštećenja uređaja ili ozljeda kupca.



Pro zajištění Vaší bezpečnosti musí být během této procedury jeden z náhradních napájecích systémů vypnut a odpojen. Chyba při volbě správného napájecího systému může vést k vážné osobní újmě nebo zničení jednotky.



Fare: Et af sikkerhedsstrømsystemerne skal slukkes, og stikket skal tages ud under denne procedure for at undgå at få stød. Hvis ikke det rigtige strømsystem vælges, kan det resultere i alvorlige personskader eller ødelæggelse af kundens enhed.



Fare: Du må slå av og koble fra ett av de ekstra strømforsyningssystemene mens du utfører denne prosedyren så du ikke utsettes for fare. Valg av feil strømforsyningssystem kan føre til alvorlig personskade eller at kundens enhet går tapt.



Vaara: Tämän toiminnon ajaksi toisesta jännitelähteestä on katkaistava virta ja sen liittimet on irrotettava, jotta toiminto olisi turvallinen. Väärän jännitelähteen valinta voi aiheuttaa vakavan vamman tai laitteen vioittumisen.



Danger: Un des systèmes d'alimentation redondante doit être éteint et débranché durant cette procédure afin de préserver votre sécurité. Une erreur dans la sélection du système d'alimentation pourrait entraîner de graves blessures ainsi que la perte de l'unité pour le client.



Vorsicht: Aus Sicherheitsgründen müssen während dieses Vorgangs eines der redundanten Stromversorgungssysteme ausgeschaltet und das zugehörige Kabel herausgezogen werden. Das Auswählen des falschen Stromversorgungssystems kann zu Verletzungen oder dem Verlust der Einheit führen.



VIGYÁZAT, VESZÉLY!

A tartalékolt tápellátó rendszer egyikét ki kell kapcsolni és ki kell húzni ennek az eljárásnak a során, az Ön biztonsága érdekében!

A megfelelő tápellátó rendszer téves kiválasztása a felhasználó súlyos személyi sérülését vagy az egység kiesését eredményezheti.



Pericolo: Per sicurezza, uno dei sistemi di alimentazione di scorta deve essere spento e scollegato durante questa procedura. Se non si seleziona il sistema di alimentazione corretto, si possono produrre gravi lesioni alle persone oppure la perdita dell'unità per il cliente.



危険: この手順を実行している間は、安全のためにパワー・システムの一方は、電源を切って電源プラグを抜いておく必要があります。正しい定格のパワー・システムを選択しなかった場合は、重大な人身事故を引き起こしたり、あるいはお客様の装置に損傷を与えることがあります。



위험

사용자의 안전을 보장받으려면 이 절차 동안에 여분의 전원 시스템중 하나를 반드시 끄고 플러그도 빼십시오. 올바른 전원 시스템이 선택되지 않으면, 심각한 신체적 피해를 입게되거나 고객의 장비에 손상을 주게 됩니다.



Fare: Du må slå av og koble fra ett av de ekstra strømforsyningssystemene mens du utfører denne prosedyren så du ikke utsettes for fare. Valg av feil strømforsyningssystem kan føre til alvorlig personskade eller at kundens enhet går tapt.



Niebezpieczeństwo: Dla bezpieczeństwa jeden z nadmiarowych systemów zasilania musi być wyłączony, a wtyk odłączony. Wybranie niewłaściwego systemu zasilania może spowodować poważne obrażenia lub uszkodzenie urządzenia.



Perigo: Para segurança do utilizador, durante este procedimento, um dos sistemas de alimentação de reserva deve ser desligado e o cabo de alimentação retirado da respectiva tomada. A selecção de um sistema de alimentação incorrecto pode resultar em lesões pessoais graves ou na impossibilidade de utilização da unidade por parte do cliente.



Опасно:
В целях безопасности во время данной процедуры один из резервных блоков питания следует выключить и отсоединить от сети. В случае ошибки при выборе правильного блока питания вы можете получить серьезные повреждения, а заказчик может лишиться своего устройства.



Peligro: Uno de los sistemas de alimentación redundante, debe ser apagado y desenchufado durante este procedimiento para cuidar de su seguridad. No seleccionar la correcta alimentación del sistema puede producir serias lesiones personales a la pérdida de la unidad del cliente.



Fara: Ett av de redundanta kraftsystemen måste stängas av och kopplas ur innan den här proceduren påbörjas. Ett felaktigt val av kraftsystem kan resultera i allvarliga person- och/eller maskinskador.

Caution Notice

Warning: In order to minimize laser exposure, do not press more than one "Test Laser" button at a time or have more than one Test jumper installed at a time. Remove all Test jumpers after measurements and troubleshooting are complete.

Waarschuwing:

Om blootstelling aan laserstralen tot een minimum te beperken, mag u op slechts één "Test Laser"-knop tegelijk drukken of mag er niet meer dan één test-jumper tegelijk geïnstalleerd zijn. Eens de metingen en de probleembepaling voltooid zijn, moet u alle test-jumpers verwijderen.

Cuidado:

Para minimizar exposição a laser, não pressione mais de um botão "Laser de Teste" ao mesmo tempo ou tenha instalado mais de um jumper de teste de uma vez. Remova todos os jumpers de teste depois que as medições e a detecção de problemas estejam concluídas.

警告：为使激光暴光减少到最低限度，请不要同时按一个以上的测试激光按钮。

- Ovaj postupak treba obavljati s oba redundantna izvora napajanja iskjučenim da bi osigurali vasu sigurnost i spriječili moguća oštećenja udedjaja.

Aby se omezilo ozáření laserem na minimum, nepoužívejte současně více než jedno tlačítko nebo jednu propojku najednou. Po dokončení měření nebo opravy odstraňte všechny zkušební propojky.

Pas på! Tryk kun én gang på knappen "Test laser", og installér kun én test-jumper ad gangen for at minimere laserstrålingen. Fjern alle test-jumpere, når målingerne og fejlfindingen er afsluttet.

Advarsel: For å gjøre faren for kontakt med laserstråling mindre må du ikke trykke på mer enn EN "Test Laser"-knapp av gangen eller ha installert mer enn EN testvelger av gangen. Fjern alle testvelgere når du er ferdig med målinger og feilsøking.

Varoitus: Jotta välttäisit lasersäteille altistumista, älä paina useampaa kuin yhtä "Test Laser" -painiketta kerrallaan äläkä käytä useampaa kuin yhtä testihyppyjohtinta kerrallaan. Poista testihyppyjohtimet mittausten ja vianmäärityksen jälkeen.

Attention Afin de minimiser l'exposition aux rayons laser, n'appuyez pas en même temps sur plus d'un bouton "Test du Laser" ou alors assurez-vous que plusieurs cavaliers de test sont installés. Retirez tous les cavaliers de tests après avoir effectué les mesures et les mises au point.

Achtung: Um die Laserstrahlung so gering wie möglich zu halten, nicht mehr als jeweils einen Knopf "Test-Laser" drücken oder mehr als eine Testbrücke gleichzeitig installieren. Nach Abschluß der Messungen und Fehlerbehebung alle Testbrücken entfernen.

FIGYELMEZTETÉS!

A lézersugárzás minimalizálása érdekében ne nyomjon be egyenél több Lézer Teszt gombot vagy ne helyezzen be egyenél több teszt átkötést egyszerre!
A mérések után vegye ki az összes teszt átkötést, s ezzel a hibakeresés befejeződött.

Attenzione: Per ridurre al minimo l'esposizione al laser, non premere più di un pulsante 'Test Laser' (per la prova del laser) alla volta e non installare più di un jumper di prova alla volta. Rimuovere tutti i jumper di prova al termine delle procedure di misurazione e di ricerca guasti.

注意：レーザーにさらされるのを最小限にするために、“Test Laser” ボタンを一度に2回以上押ししたり、あるいはテスト・ジャンパーを一度に2つ以上取り付けたりしないでください。測定およびトラブルシューティングが終了したら、テスト・ジャンパーはすべて取り外してください。

주의

레이저 누출을 최소화하려면, 한번에 하나이상의 "레이저 테스트" 버튼을 누르지 말고, 한번에 하나이상의 테스트 점퍼를 설치하지 마십시오. 측정 및 고장 수리가 완료된 후에는 모든 테스트 점퍼를 제거하십시오.

Advarsel: For å gjøre faren for kontakt med laserstråling mindre må du ikke trykke på mer enn EN "Test Laser"-knapp av gangen eller ha installert mer enn EN testvelger av gangen. Fjern alle testvelgere når du er ferdig med målinger og feilsøking.

Ostrzeżenie: Aby zmniejszyć szkodliwe promieniowanie lasera, nie należy naciskać jednocześnie więcej niż jednego przycisku "Test Laser" ani instalować jednocześnie więcej niż jednej zworki (jumper). Po zakończeniu pomiarów i testów należy usunąć wszystkie zworki testowe.

Cuidado: De modo a minimizar o risco de exposição a radiações laser, prima ap um botão "Test laser" ou instale apenas um jumper de teste, de cada vez. Após a conclusão das medições e determinação e re problemas, remova todos os jumpers de teste.

Осторожно:
Чтобы не подвергать себя излишнему лазерному излучению, во время одного сеанса работы нажимайте кнопку "Laser Test" только один раз и устанавливайте только одну тестовую перемычку. По окончании измерений и устранения неисправностей снимите все тестовые перемычки.

Precaución: Para minimizar la exposición al laser, no pulse más de un botón "Test Laser (Prueba de Laser)" al mismo tiempo ni tenga instalada más de una prueba de puente al mismo tiempo. Elimine todas las pruebas de puentes después de que se hayan realizado las mediciones y la resolución de problemas.

Varning: För att minimera mängden laserljus, bör du undvika att trycka på mer än en "Test Laser"-knapp eller installera mer än en testbygel åt gången. Ta bort alla testbyglar när mätning och felsökning är avslutad.

Appendix B. 9729 Wiring and Power Plug Information

This appendix contains simplified wiring diagrams of the 9729 power circuitry and information about power plug requirements.

Simplified Wiring Diagrams

Wiring for 9729 with Redundant Power System

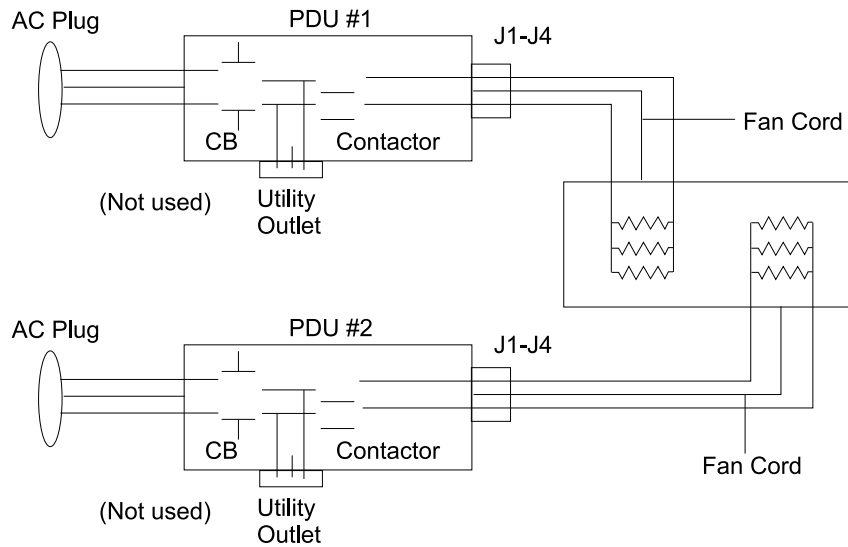

Figure 24. 9729 Redundant Power System

Wiring for 9729 without Redundant Power System

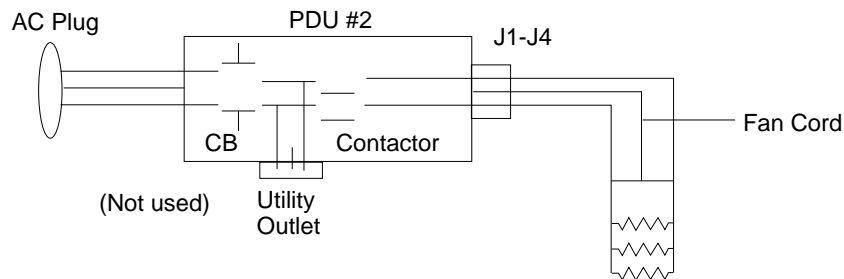

Figure 25. 9729 Non-redundant Power System

Power Plug Requirements

<p>2 6</p> <p>250V 10A</p> 	<p>23</p> <p>250V 13A</p> 
<p>5</p> <p>250V 15A</p> 	<p>24</p> <p>250V 10A</p> 
<p>18</p> <p>250V 16A</p> 	<p>25</p> <p>250V 16A</p> 
<p>10</p> <p>250V 10A</p> 	<p>32</p> <p>250V 6-16A</p> 
<p>22</p> <p>250V 16A</p> 	<p>19</p> <p>250V 15A</p> 

Figure 26. 9729 Power Plug Identification

Figure 27. Power Plug Requirements by Country (200–250 volts)

Country	Plug	Country	Plug	Country	Plug
Afghanistan	18	Hungary	18	Saudi Arabia	18
Angola	18	Iceland	18	Sierra Leone	23
Antigua	23	India	23	Singapore	23
ARAMCO	18	Indonesia	18	Slovakia (Republic of)	18
Argentina	2	Iran	18	Slovenia	18
Armenia	18	Iraq	23	Somalia	23
Aruba	5	Ireland	23	South Africa	22
Australia	6	Israel	32	Spain	18
Austria	18	Italy	25	Sri Lanka	22
Azerbaijan	18	Jamaica	5	Sudan	18
Bahamas	5	Japan	5	Swaziland	18
Bahrein	23	Jordan	23	Sweden	18
Bangladesh	22	Kazakhstan	18	Switzerland	24
Barbados	5	Kenya	23	Syria	18
Belgium	18	Kirgizstan	18	Tadzhikstan	18
Belorussia	18	Korea (Republic of)	18	Taiwan	5
Bermuda	23	Kuwait	23	Tanzania	23
Bolivia	5	Latvia	18	Thailand	5
Brazil	5	Lebanon	18	Trinidad and Tobago	5
Brunei	23	Libya	25	Turkey	18
Bulgaria	18	Liechtenstein	24	Turkmenistan	18
Channel Islands	23	Lithuania	18	Uganda	23
Chile	25	Luxembourg	18	Ukraine	18
Colombia	2	Macau	18	United Arab Emirates	23
Costa Rica	5	Malawi	23	United Kingdom	23
Croatia	18	Malaysia	23	Uruguay	2
Curacao	5	Malta	23	Uzbekistan	18
Cyprus	23	Mexico	10	Venezuela	5
Czech Republic	18	Moldavia	18	Western Samoa	6
Denmark	19	Mozambique	18	Yemen	23
Dominican Republic	5	Myanmar	22	Yugoslavia	18
Dubai	23	Nepal	23	Zaire	18
Ecuador	5	Netherlands	18	Zambia	23
Egypt	18	Netherlands Antilles	5	Zimbabwe	18
El Salvador	5	New Zealand	6		
Estonia	18	Nicaragua	5		
Ethiopia	25	Nigeria	23		
Finland	18	Norway	18		
Fiji	23	Oman	23		
Germany	18	Pakistan	22		
Georgia	18	Panama	5		
France	18	Paraguay	2		
France Overseas	18	Peoples' Rep of China	23		
Ghana	23	Peru	5		
Greece	18	Philippines	5		
Guatemala	5	Poland	18		
Guyana	23	Portugal	18		
Haiti	5	Qatar	23		
Honduras	5	Romania	18		
Hong Kong	23	Russia	18		

Index

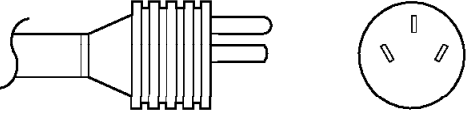
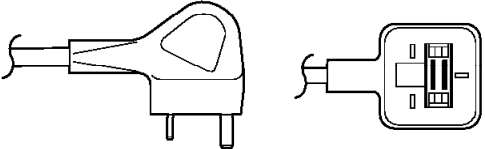
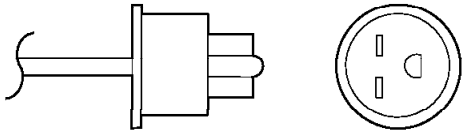
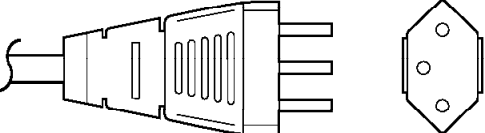
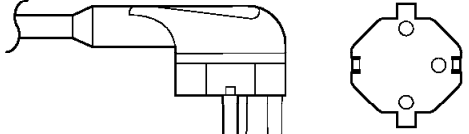
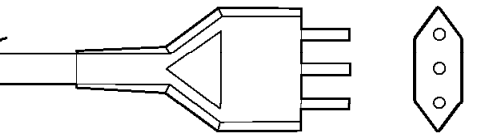
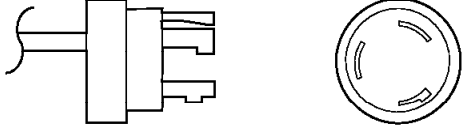
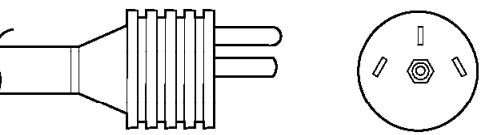
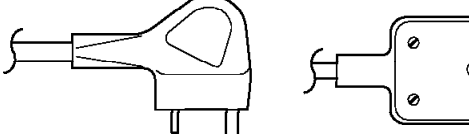
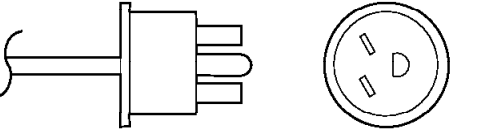
B

backplane, removing and replacing 51

C

cable specifications, single-mode trunk 4
card cage/grating, removing and replacing 56
coaxial cable, removing and replacing 61

D

diagnostic card, removing and replacing 35
diagrams, wiring 79
dropdown panel, removing and replacing 55
Dual Fiber I/O Card, removing and replacing 40

E

environmental requirements 4

F

fan filter, removing and replacing 53
fan tray, removing and replacing 51
Fiber I/O Card, removing and replacing 40
front panel reference 2

G

generic card, removing and replacing 31
grating assembly, removing and replacing 41
grating fan, removing and replacing 60

I

inspection, safety viii
installation 7
introduction 2
IOC, removing and replacing 39

L

LRC, removing and replacing 34

M

maintenance, periodic 29
models of the 9729 1

N

notices xiii

O

optical adapters, removing and replacing 43

P

panel, front 2
PDU, removing and replacing 45
periodic maintenance 29
physical description 4
power plug requirements 80
power supply, removing and replacing 48
procedures, troubleshooting 11

R

reference, front panel 2
removal and replacement
backplane 51
card cage/grating 56
coaxial cable 61
diagnostic card 35
dropdown panel 55
fan cable 54
fan cable, removing and replacing 54
fan filter 53
fan tray 51
Fiber I/O Card and Dual Fiber I/O Card 40
generic card 31
grating assembly 41
grating fan 60
IOC 39
LRC 34
maintenance 29
measuring optical power and tuning LRC
wavelength 30
optical adapters 43
PDU 45
power supply 48
required test equipment 11, 29
TEC Card 38
testing open-fiber detection circuitry 62

S

safety inspection procedures viii
safety notices 65
single-mode trunk cable specifications 4

T

TEC Card, removing and replacing 38

trademarks xv
troubleshooting procedures 11

W

wiring diagrams 79

Tell Us What You Think!

9729 Optical Wavelength Division Multiplexer Maintenance Information

Publication No. GY27-0357-02

We hope you find this publication useful, readable, and technically accurate, but only you can tell us! Your comments and suggestions will help us improve our technical publications. Please take a few minutes to let us know what you think by completing this form. If you are in the U.S.A., you can mail this form postage free or fax it to us at 1-800-253-3520. Elsewhere, your local IBM branch office or representative will forward your comments or you may mail them directly to us.

Overall, how satisfied are you with the information in this book?	Satisfied	Dissatisfied
	<input type="checkbox"/>	<input type="checkbox"/>

How satisfied are you that the information in this book is:	Satisfied	Dissatisfied
Accurate	<input type="checkbox"/>	<input type="checkbox"/>
Complete	<input type="checkbox"/>	<input type="checkbox"/>
Easy to find	<input type="checkbox"/>	<input type="checkbox"/>
Easy to understand	<input type="checkbox"/>	<input type="checkbox"/>
Well organized	<input type="checkbox"/>	<input type="checkbox"/>
Applicable to your task	<input type="checkbox"/>	<input type="checkbox"/>

Specific comments or problems:

Please tell us how we can improve this book:

Thank you for your comments. If you would like a reply, provide the necessary information below.

Name

Address

Company or Organization

Phone No.



Fold and Tape

Please do not staple

Fold and Tape



NO POSTAGE
NECESSARY
IF MAILED IN THE
UNITED STATES

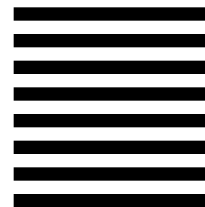

BUSINESS REPLY MAIL

FIRST-CLASS MAIL PERMIT NO. 40 ARMONK, NEW YORK

POSTAGE WILL BE PAID BY ADDRESSEE

Design & Information Development
Dept. CGF/Bldg. 656
International Business Machines Corporation
PO BOX 12195
RESEARCH TRIANGLE PARK NC 27709-9990



Fold and Tape

Please do not staple

Fold and Tape



Part Number: 85H7321

Printed in USA

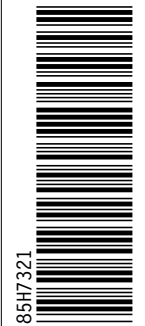

GY27-0357-02

